

Ecoglo International Limited

Technical Manual
for
Photoluminescent Egress Path Markings



Contents:

Photoluminescent Egress Path Markings Specification.....3

Appendices.....28

PHOTOLUMINESCENT EGRESS PATH MARKINGS

Part 1 DESCRIPTION

1.01 System Description

Approved photoluminescent egress path markings as per 1.02 below delineating the Means of Egress shall be provided in buildings as required by relevant building code.

1.02 Markings within Exit Components

Photoluminescent egress path markings shall be provided in all interior and exterior exit stairways, exit ramps and exit passageways of the Means of Egress, in accordance with Sections 1.02a. through 1.02f.

a. Steps

A solid and continuous stripe shall be applied to the horizontal leading edge of each step and shall extend to within 50 mm of each end of the leading edge of the step. Stripes shall have a minimum horizontal width of 10 mm and a maximum width of 50 mm. The leading edge of the stripe shall be placed not more than 15 mm from the leading edge of the step and the stripe shall not overlap the leading edge of the step by more than 5 mm down the vertical face of the step.

b. Landings

The leading edge of landings shall be marked with a stripe consistent with the dimensional requirements for steps.

c. Handrails

Handrails and handrail extensions shall be marked with a solid and continuous stripe having a minimum width of 10 mm. The stripe shall be placed on the top surface of, or inside surface of, or on the wall immediately adjacent to and within 100 mm, of the handrail for the entire length of the handrail. Where handrails or handrail extensions bend or turn corners, the stripe shall not have a gap of more than 100 mm.

d. Perimeter Demarcation Lines

Stair landings and other floor areas within all interior and exterior exit stairways, interior and exterior exit ramps and exit passageways, with the exception of the sides of steps, shall be provided with solid and continuous demarcation lines on the floor or on the walls or a combination of both. The stripes shall be 10 mm to 50 mm wide with interruptions not exceeding 100 mm.

Demarcation lines shall not extend in front of or across doors that lead out of an exit through which occupants must travel to complete the Means of Egress.

e. Obstacles

Obstacles at or below 2000 mm in height and projecting more than 100 mm into the egress path shall be outlined with markings not less than 25 mm in width comprised of a pattern of alternating equal bands of photoluminescent material and black.

f. Doors within The Means of Egress

Doors through which occupants must pass in order to complete the Means of Egress shall be provided with markings complying with Sections f.(i) through f.(iii).

(i) Emergency Exit Symbol

The doors shall be identified by a low-location photoluminescent emergency exit symbol complying with NFPA 170. The exit symbol shall be a minimum of 100 mm in height and shall be mounted on the door, centred horizontally, with the top of the symbol no higher than 500 mm above the finished floor.

(ii) Door Hardware Markings

Door hardware shall be marked with no less than 100 mm x 100 mm or equivalent area of photoluminescent material. This marking shall be located behind, immediately adjacent to or on the door handle or escutcheon. Where a panic bar is installed, such material shall be not less than 15 mm wide for the entire length of the actuating bar or touchpad.

(iii) Door Frame Markings

The top and sides of the door frame shall be marked with a solid and continuous 10 mm to 50 mm wide stripe. Where the door molding does not provide sufficient flat surface on which to locate the stripe, the stripe shall be permitted to be located on the wall surrounding the frame.

1.03 Approved Photoluminescent Markings

Approved photoluminescent egress path markings shall:

- a) Be tested to meet UL 1994 and all such products shall be listed with Underwriters Laboratory by the manufacturer; **AND**
- b) Be produced using a High Temperature Curing (HTC) manufacturing process and independently tested to support the criteria detailed in following clause 2.04j.; **AND**
- c) Be produced by a manufacturer with ISO 9001 Quality Assurance certification; **AND**
- d) Be warranted to last a minimum of 30 years indoors.

1.04 Illumination

Where photoluminescent exit path markings are installed, they shall be provided with not less than 10 lux of illumination for not less than 60 minutes prior to periods when the building is occupied, and continuously during the building occupancy.

1.05 Submittals

Documentation as detailed in 1.05a. through 1.05c. must be submitted.

a. Manufacturer's Product Data Sheets

Submit Product Data Sheets for product number verification. See Appendix 1.

b. Manufacturer's Installation Instructions

Submit installation instructions. See Appendix 2.

c. Test Reports

Submit independent test reports to verify compliance with relevant standards as detailed in Section 2.04 Performance Criteria. See Appendix 3.

1.06 Quality Assurance

Submit copy of Manufacturer's ISO 9001-2016 Quality Assurance documentation. See Appendix 4.

1.07 Warranties

Submit warranty for luminance characteristics for a minimum 30 years of indoor use. See Appendix 5.

Part 2 MATERIALS REQUIREMENTS

2.01 Ecoglo photoluminescent path markings to meet UL 1994

a. Acceptable Manufacturer: Ecoglo International Limited

b. Authorised Representative: Ecoglo International Limited

Contact:

Keith Phillips

Ecoglo International Limited

Address: D1 Lot Concepcion Street,
JLL Building #2, Barangay Pag-asa,
Binangonan Rizal 1940, Philippines

Trunkline: +632-7915-9355

Direct: +632-7218-1848

Cell: +63917-514-6803 / +63927-033-3496 /
+63928-279-7527

Email: keith.phillips@ecoglo.com

Web: www.ecoglo.com

2.02 Materials Composition

a. Aluminium Base Products

(i) Extruded aluminium nosing profile:
6060T5 or 6063T5 aluminium extrusion.

(ii) Extruded aluminium inserts for bonding into nosing profile:
Powder coated 6060T5 or 6063T5 aluminium extrusion.

(ii) Photoluminescent and anti-slip material in aluminium extrusion:
Photoluminescent pigment and silicon carbide anti-slip materials embedded in thermoset polyester manufactured using a High Temperature Curing (HTC) process at a temperature

exceeding 160°C to integrally bond the active ingredients into the powder coated aluminium insert resulting in the photoluminescent material being recessed into the protective channels of the powder coated aluminium extrusion.

(iii) Photoluminescent signs and markers:

Photoluminescent pigment embedded in thermoset polyester manufactured using a High Temperature Curing (HTC) process at a temperature exceeding 160°C to integrally bond the active ingredients to 5005 0.9mm aluminium sheet.

2.03 Approved Products

a. Steps and b. Landings

Step nosings and step edgings for marking step edges and the leading edge of landings consisting of materials and manufactured using processes as defined in section 2.02.

Product Code	Product Description	Product Length	Unit
F15-175-800	Step Nosing 75mm x 33mm, drilled with fixers, includes black anti-slip strip	800mm	each
F15-175-900	Step Nosing 75mm x 33mm, drilled with fixers, includes black anti-slip strip	900mm	each
F15-175-1000	Step Nosing 75mm x 33mm, drilled with fixers, includes black anti-slip strip	1000mm	each
F15-175-1100	Step Nosing 75mm x 33mm, drilled with fixers, includes black anti-slip strip	1100mm	each
F15-175-1200	Step Nosing 75mm x 33mm, drilled with fixers, includes black anti-slip strip	1200mm	each
F15-175-1300	Step Nosing 75mm x 33mm, drilled with fixers, includes black anti-slip strip	1300mm	each
F15-175-1400	Step Nosing 75mm x 33mm, drilled with fixers, includes black anti-slip strip	1400mm	each

F15-175-1500	Step Nosing 75mm x 33mm, drilled with fixers, includes black anti-slip strip	1500mm	each
F15-175-2450	Step Nosing 75mm x 33mm, includes black anti-slip strip, packed as 2 components, fixers included, FULL LENGTH	2450mm	each
F15-175-3060	Step Nosing 75mm x 33mm, includes black anti-slip strip, packed as 2 components, fixers included, FULL LENGTH	3060mm	each
F14-175-800	Step Nosing 75mm x 10mm, drilled with fixers, includes black anti-slip strip	800mm	each
F14-175-900	Step Nosing 75mm x 10mm, drilled with fixers, includes black anti-slip strip	900mm	each
F14-175-1000	Step Nosing 75mm x 10mm, drilled with fixers, includes black anti-slip strip	1000mm	each
F14-175-1100	Step Nosing 75mm x 10mm, drilled with fixers, includes black anti-slip strip	1100mm	each
F14-175-1200	Step Nosing 75mm x 10mm, drilled with fixers, includes black anti-slip strip	1200mm	each
F14-175-1300	Step Nosing 75mm x 10mm, drilled with fixers, includes black anti-slip strip	1300mm	each
F14-175-1400	Step Nosing 75mm x 10mm, drilled with fixers, includes black anti-slip strip	1400mm	each
F14-175-1500	Step Nosing 75mm x 10mm, drilled with fixers, includes black anti-slip strip	1500mm	each

F14-175-2450	Step Nosing 75mm x 10mm, includes black anti-slip strip, packed as 2 components, fixers included, FULL LENGTH	2450mm	each
F14-175-3060	Step Nosing 75mm x 10mm, includes black anti-slip strip, packed as 2 components, fixers included, FULL LENGTH	3060mm	each
F15-173-800	Step Nosing 75mm x 33mm, drilled with fixers, includes black anti-slip strip	800mm	each
F15-173-900	Step Nosing 75mm x 33mm, drilled with fixers, includes black anti-slip strip	900mm	each
F15-173-1000	Step Nosing 75mm x 33mm, drilled with fixers, includes black anti-slip strip	1000mm	each
F15-173-1100	Step Nosing 75mm x 33mm, drilled with fixers, includes black anti-slip strip	1100mm	each
F15-173-1200	Step Nosing 75mm x 33mm, drilled with fixers, includes black anti-slip strip	1200mm	each
F15-173-1300	Step Nosing 75mm x 33mm, drilled with fixers, includes black anti-slip strip	1300mm	each
F15-173-1400	Step Nosing 75mm x 33mm, drilled with fixers, includes black anti-slip strip	1400mm	each
F15-173-1500	Step Nosing 75mm x 33mm, drilled with fixers, includes black anti-slip strip	1500mm	each
F15-173-2450	Step Nosing 75mm x 33mm, includes black anti-slip strip, packed as 2 components, fixers included, FULL LENGTH	2450mm	each

F15-173-3060	Step Nosing 75mm x 33mm, includes black anti-slip strip, packed as 2 components, fixers included, FULL LENGTH	3060mm	each
F14-173-800	Step Nosing 75mm x 10mm, drilled with fixers, includes black anti-slip strip	800mm	each
F14-173-900	Step Nosing 75mm x 10mm, drilled with fixers, includes black anti-slip strip	900mm	each
F14-173-1000	Step Nosing 75mm x 10mm, drilled with fixers, includes black anti-slip strip	1000mm	each
F14-173-1100	Step Nosing 75mm x 10mm, drilled with fixers, includes black anti-slip strip	1100mm	each
F14-173-1200	Step Nosing 75mm x 10mm, drilled with fixers, includes black anti-slip strip	1200mm	each
F14-173-1300	Step Nosing 75mm x 10mm, drilled with fixers, includes black anti-slip strip	1300mm	each
F14-173-1400	Step Nosing 75mm x 10mm, drilled with fixers, includes black anti-slip strip	1400mm	each
F14-173-1500	Step Nosing 75mm x 10mm, drilled with fixers, includes black anti-slip strip	1500mm	each
F14-173-2450	Step Nosing 75mm x 10mm, includes black anti-slip strip, packed as 2 components, fixers included, FULL LENGTH	2450mm	each
F14-173-3060	Step Nosing 75mm x 10mm, includes black anti-slip strip packed as 2 components, fixers included, FULL LENGTH	3060mm	each

F15-155-800	Step Nosing 75mm x 33mm, drilled with fixers, includes yellow anti-slip strip	800mm	each
F15-155-900	Step Nosing 75mm x 33mm, drilled with fixers, includes yellow anti-slip strip	900mm	each
F15-155-1000	Step Nosing 75mm x 33mm, drilled with fixers, includes yellow anti-slip strip	1000mm	each
F15-155-1100	Step Nosing 75mm x 33mm, drilled with fixers, includes yellow anti-slip strip	1100mm	each
F15-155-1200	Step Nosing 75mm x 33mm, drilled with fixers, includes yellow anti-slip strip	1200mm	each
F15-155-1300	Step Nosing 75mm x 33mm, drilled with fixers, includes yellow anti-slip strip	1300mm	each
F15-155-1400	Step Nosing 75mm x 33mm, drilled with fixers, includes yellow anti-slip strip	1400mm	each
F15-155-1500	Step Nosing 75mm x 33mm, drilled with fixers, includes yellow anti-slip strip	1500mm	each
F15-155-2450	Step Nosing 75mm x 33mm, includes yellow anti-slip strip, packed as 2 components, fixers included, FULL LENGTH	2450mm	each
F15-155-3060	Step Nosing 75mm x 33mm, includes yellow anti-slip strip, packed as 2 components, fixers included, FULL LENGTH	3060mm	each
F14-155-800	Step Nosing 75mm x 10mm, drilled with fixers, includes yellow anti-slip strip	800mm	each

F14-155-900	Step Nosing 75mm x 10mm, drilled with fixers, includes yellow anti-slip strip	900mm	each
F14-155-1000	Step Nosing 75mm x 10mm, drilled with fixers, includes yellow anti-slip strip	1000mm	each
F14-155-1100	Step Nosing 75mm x 10mm drilled with fixers, includes yellow anti-slip strip	1100mm	each
F14-155-1200	Step Nosing 75mm x 10mm, drilled with fixers, includes yellow anti-slip strip	1200mm	each
F14-155-1300	Step Nosing 75mm x 10mm, drilled with fixers, includes yellow anti-slip strip	1300mm	each
F14-155-1400	Step Nosing 75mm x 10mm, drilled with fixers, includes yellow anti-slip strip	1400mm	each
F14-155-1500	Step Nosing 75mm x 10mm, drilled with fixers, includes yellow anti-slip strip	1500mm	each
F14-155-2450	Step Nosing 75mm x 10mm, includes yellow anti-slip strip, packed as 2 components, fixers included, FULL LENGTH	2450mm	each
F14-155-3060	Step Nosing 75mm x 10mm, includes yellow anti-slip strip, packed as 2 components, fixers included, FULL LENGTH	3060mm	each
F2-003-800	Step Nosing 77mm x 22mm, insert glued in, drilled with fixers	800mm	each
F2-003-900	Step Nosing 77mm x 22mm, insert glued in, drilled with fixers	900mm	each
F2-003-1000	Step Nosing 77mm x 22mm, insert glued in, drilled with fixers	1000mm	each
F2-003-1100	Step Nosing 77mm x 22mm, insert glued in, drilled with fixers	1100mm	each

F2-003-1200	Step Nosing 77mm x 22mm, insert glued in, drilled with fixers	1200mm	each
F2-003-1300	Step Nosing 77mm x 22mm, insert glued in, drilled with fixers	1300mm	each
F2-003-1400	Step Nosing 77mm x 22mm, insert glued in, drilled with fixers	1400mm	each
F2-003-1500	Step Nosing 77mm x 22mm, insert glued in, drilled with fixers	1500mm	each
F2-003-2450	Step Nosing 77mm x 22mm, insert glued in, drilling required on-site, fixers included, FULL LENGTH	2450mm	each
F2-003-3060	Step Nosing 77mm x 22mm, insert glued in, drilling required on-site, fixers included, FULL LENGTH	3060mm	each
E2-071-800	Step Edge Contrast 37mm, includes black anti-slip strip	800mm	each
E2-071-900	Step Edge Contrast 37mm, includes black anti-slip strip	900mm	each
E2-071-1000	Step Edge Contrast 37mm, includes black anti-slip strip	1000mm	each
E2-071-1100	Step Edge Contrast 37mm, includes black anti-slip strip	1100mm	each
E2-071-1200	Step Edge Contrast 37mm, includes black anti-slip strip	1200mm	each
E2-071-1300	Step Edge Contrast 37mm, includes black anti-slip strip	1300mm	each
E2-071-1400	Step Edge Contrast 37mm, includes black anti-slip strip	1400mm	each
E2-071-1500	Step Edge Contrast 37mm, includes black anti-slip strip	1500mm	each

E2-071-2450	Step Edge Contrast 37mm, includes black anti-slip strip, FULL LENGTH	2450mm	each
E2-071-3060	Step Edge Contrast 37mm, includes black anti-slip strip FULL LENGTH	3060mm	each
E2-071P-800	Step Edge Contrast 37mm, Punched, includes black anti-slip strip	800mm	each
E2-071P-900	Step Edge Contrast 37mm, Punched, includes black anti-slip strip	900mm	each
E2-071P-1000	Step Edge Contrast 37mm, Punched, includes black anti-slip strip	1000mm	each
E2-071P-1100	Step Edge Contrast 37mm, Punched, includes black anti-slip strip	1100mm	each
E2-071P-1200	Step Edge Contrast 37mm, Punched, includes black anti-slip strip	1200mm	each
E2-071P-1300	Step Edge Contrast 37mm, Punched, includes black anti-slip strip	1300mm	each
E2-071P-1400	Step Edge Contrast 37mm, Punched, includes black anti-slip strip	1400mm	each
E2-071P-1500	Step Edge Contrast 37mm, Punched, includes black anti-slip strip	1500mm	each
E2-071P-2450	Step Edge Contrast 37mm, Punched, includes black anti-slip strip, FULL LENGTH	2450mm	each
E2-071P-3060	Step Edge Contrast 37mm, Punched, includes black anti-slip strip, FULL LENGTH	3060mm	each
E14-075-800	Step Edge Contrast 64mm, includes black anti-slip strip	800mm	each

E14-075-900	Step Edge Contrast 64mm, includes black anti-slip strip	900mm	each
E14-075-1000	Step Edge Contrast 64mm, includes black anti-slip strip	1000mm	each
E14-075-1100	Step Edge Contrast 64mm, includes black anti-slip strip	1100mm	each
E14-075-1200	Step Edge Contrast 64mm, includes black anti-slip strip	1200mm	each
E14-075-1300	Step Edge Contrast 64mm, includes black anti-slip strip	1300mm	each
E14-075-1400	Step Edge Contrast 64mm, includes black anti-slip strip	1400mm	each
E14-075-1500	Step Edge Contrast 64mm, includes black anti-slip strip	1500mm	each
E14-075-2450	Step Edge Contrast 64mm, includes black anti-slip strip, FULL LENGTH	2450mm	each
E14-075-3060	Step Edge Contrast 64mm, includes black anti-slip strip, FULL LENGTH	3060mm	each
E14-075P-800	Step Edge Contrast 64mm, Punched, includes black anti-slip strip	800mm	each
E14-075P-900	Step Edge Contrast 64mm, Punched, includes black anti-slip strip	900mm	each
E14-075P-1000	Step Edge Contrast 64mm, Punched, includes black anti-slip strip	1000mm	each
E14-075P-1100	Step Edge Contrast 64mm Punched includes black anti-slip strip	1100mm	each

E14-075P-1200	Step Edge Contrast 64mm, Punched, includes black anti-slip strip	1200mm	each
E14-075P-1300	Step Edge Contrast 64mm, Punched, includes black anti-slip strip	1300mm	each
E14-075P-1400	Step Edge Contrast 64mm, Punched, includes black anti-slip strip	1400mm	each
E14-075P-1500	Step Edge Contrast 64mm, Punched, includes black anti-slip strip	1500mm	each
E14-075P-2450	Step Edge Contrast 64mm, Punched, includes black anti-slip strip, FULL LENGTH	2450mm	each
E14-075P-3060	Step Edge Contrast 64mm, Punched, includes black anti-slip strip, FULL LENGTH	3060mm	each
E15-073-800	Step Edge Contrast 64mm, includes black anti-slip strip	800mm	each
E15-073-900	Step Edge Contrast 64mm, includes black anti-slip strip	900mm	each
E15-073-1000	Step Edge Contrast 64mm, includes black anti-slip strip	1000mm	each
E15-073-1100	Step Edge Contrast 64mm, includes black anti-slip strip	1100mm	each
E15-073-1200	Step Edge Contrast 64mm, includes black anti-slip strip	1200mm	each
E15-073-1300	Step Edge Contrast 64mm, includes black anti-slip strip	1300mm	each
E15-073-1400	Step Edge Contrast 64mm, includes black anti-slip strip	1400mm	each
E15-073-1500	Step Edge Contrast 64mm, includes black anti-slip strip	1500mm	each

E15-073-2450	Step Edge Contrast 64mm, includes black anti-slip strip, FULL LENGTH	2450mm	each
E15-073-3060	Step Edge Contrast 64mm, includes black anti-slip strip, FULL LENGTH	3060mm	each
E15-073P-800	Step Edge Contrast 64mm, Punched, includes black anti-slip strip	800mm	each
E15-073P-900	Step Edge Contrast 64mm, Punched, includes black anti-slip strip	900mm	each
E15-073P-1000	Step Edge Contrast 64mm, Punched, includes black anti-slip strip	1000mm	each
E15-073P-1100	Step Edge Contrast 64mm, Punched, includes black anti-slip strip	1100mm	each
E15-073P-1200	Step Edge Contrast 64mm, Punched, includes black anti-slip strip	1200mm	each
E15-073P-1300	Step Edge Contrast 64mm, Punched, includes black anti-slip strip	1300mm	each
E15-073P-1400	Step Edge Contrast 64mm, Punched, includes black anti-slip strip	1400mm	each
E15-073P-1500	Step Edge Contrast 64mm, Punched, includes black anti-slip strip	1500mm	each
E15-073P-2450	Step Edge Contrast 64mm, Punched, includes black anti-slip strip, FULL LENGTH	2450mm	each

E15-073P-3060	Step Edge Contrast 64mm, Punched, includes black anti-slip strip, FULL LENGTH	3060mm	each
E14-055-800	Step Edge Contrast 64mm, includes yellow anti-slip strip	800mm	each
E14-055-900	Step Edge Contrast 64mm, includes yellow anti-slip strip	900mm	each
E14-055-1000	Step Edge Contrast 64mm, includes yellow anti-slip strip	1000mm	each
E14-055-1100	Step Edge Contrast 64mm, includes yellow anti-slip strip	1100mm	each
E14-055-1200	Step Edge Contrast 64mm, includes yellow anti-slip strip	1200mm	each
E14-055-1300	Step Edge Contrast 64mm, includes yellow anti-slip strip	1300mm	each
E14-055-1400	Step Edge Contrast 64mm, includes yellow anti-slip strip	1400mm	each
E14-055-1500	Step Edge Contrast 64mm, includes yellow anti-slip strip	1500mm	each
E14-055-2450	Step Edge Contrast 64mm, includes yellow anti-slip strip, FULL LENGTH	2450mm	each
E14-055-3060	Step Edge Contrast 64mm, includes yellow anti-slip strip, FULL LENGTH	3060mm	each
E14-055P-800	Step Edge Contrast 64mm, Punched, includes yellow anti-slip strip	800mm	each
E14-055P-900	Step Edge Contrast 64mm, Punched, includes yellow anti-slip strip	900mm	each

E14-055P-1000	Step Edge Contrast 64mm, Punched, includes yellow anti-slip strip	1000mm	each
E14-055P-1100	Step Edge Contrast 64mm, Punched, includes yellow anti-slip strip	1100mm	each
E14-055P-1200	Step Edge Contrast 64mm, Punched, includes yellow anti-slip strip	1200mm	each
E14-055P-1300	Step Edge Contrast 64mm, Punched, includes yellow anti-slip strip	1300mm	each
E14-055P-1400	Step Edge Contrast 64mm, Punched, includes yellow anti-slip strip	1400mm	each
E14-055P-1500	Step Edge Contrast 64mm, Punched, includes yellow anti-slip strip	1500mm	each
E14-055P-2450	Step Edge Contrast 64mm, Punched, includes yellow anti-slip strip, FULL LENGTH	2450mm	each
E14-055P-3060	Step Edge Contrast 64mm, Punched, includes yellow anti-slip strip, FULL LENGTH	3060mm	each
E4-073-800	Step Edge Contrast 51mm, includes black anti-slip strip	800mm	each
E4-073-900	Step Edge Contrast 51mm, includes black anti-slip strip	900mm	each
E4-073-1000	Step Edge Contrast 51mm, includes black anti-slip strip	1000mm	each
E4-073-1100	Step Edge Contrast 51mm, includes black anti-slip strip	1100mm	each

E4-073-1200	Step Edge Contrast 51mm, includes black anti-slip strip	1200mm	each
E4-073-1300	Step Edge Contrast 51mm, includes black anti-slip strip	1300mm	each
E4-073-1400	Step Edge Contrast 51mm, includes black anti-slip strip	1400mm	each
E4-073-1500	Step Edge Contrast 51mm, includes black anti-slip strip	1500mm	each
E4-073-2450	Step Edge Contrast 51mm, includes black anti-slip strip, FULL LENGTH	2450mm	each
E4-073-3060	Step Edge Contrast 51mm, includes black anti-slip strip, FULL LENGTH	3060mm	each
E4-073P-800	Step Edge Contrast 51mm, Punched, includes black anti-slip strip	800mm	each
E4-073P-900	Step Edge Contrast 51mm, Punched, includes black anti-slip strip	900mm	each
E4-073P-1000	Step Edge Contrast 51mm, Punched, includes black anti-slip strip	1000mm	each
E4-073P-1100	Step Edge Contrast 51mm, Punched, includes black anti-slip strip	1100mm	each
E4-073P-1200	Step Edge Contrast 51mm, Punched, includes black anti-slip strip	1200mm	each
E4-073P-1300	Step Edge Contrast 51mm, Punched, includes black anti-slip strip	1300mm	each

E4-073P-1400	Step Edge Contrast 51mm, Punched, includes black anti-slip strip	1400mm	each
E4-073P-1500	Step Edge Contrast 51mm, Punched, includes black anti-slip strip	1500mm	each
E4-073P-2450	Step Edge Contrast 51mm, Punched, includes black anti-slip strip, FULL LENGTH	2450mm	each
E4-073P-3060	Step Edge Contrast 51mm, Punched, includes black anti-slip strip, FULL LENGTH	3060mm	each
G6-003-800	Guidance Strip 26mm	800mm	each
G6-003-900	Guidance Strip 26mm	900mm	each
G6-003-1000	Guidance Strip 26mm	1000mm	each
G6-003-1100	Guidance Strip 26mm	1100mm	each
G6-003-1200	Guidance Strip 26mm	1200mm	each
G6-003-1300	Guidance Strip 26mm	1300mm	each
G6-003-1400	Guidance Strip 26mm	1400mm	each
G6-003-1500	Guidance Strip 26mm	1500mm	each
G6-003-3060	Guidance Strip 26mm, FULL LENGTH	3060mm	each
G6-003P-800	Guidance Strip 26mm, Punched, with fixers	800mm	each
G6-003P-900	Guidance Strip 26mm, Punched, with fixers	900mm	each
G6-003P-1000	Guidance Strip 26mm, Punched, with fixers	1000mm	each

G6-003P-1100	Guidance Strip 26mm, Punched, with fixers	1100mm	each
G6-003P-1200	Guidance Strip 26mm, Punched, with fixers	1200mm	each
G6-003P-1300	Guidance Strip 26mm, Punched, with fixers	1300mm	each
G6-003P-1400	Guidance Strip 26mm, Punched, with fixers	1400mm	each
G6-003P-1500	Guidance Strip 26mm, Punched, with fixers	1500mm	each
G6-003P-3060	Guidance Strip 26mm, Punched, FULL LENGTH	3060mm	each
G6-003T-800	Guidance Strip 26mm, with foam Tape	800mm	each
G6-003T-900	Guidance Strip 26mm, with foam Tape	900mm	each
G6-003T-1000	Guidance Strip 26mm, with foam Tape	1000mm	each
G6-003T-1100	Guidance Strip 26mm, with foam Tape	1100mm	each
G6-003T-1200	Guidance Strip 26mm, with foam Tape	1200mm	each
G6-003T-1300	Guidance Strip 26mm, with foam Tape	1300mm	each
G6-003T-1400	Guidance Strip 26mm, with foam Tape	1400mm	each
G6-003T-1500	Guidance Strip 26mm, with foam Tape	1500mm	each
G6-003T-3060	Guidance Strip 26mm, with foam Tape, FULL LENGTH	3060mm	each

c. Handrails

Rounded Handrails

Handrail markers for marking of rounded handrails consisting of materials and manufactured using processes as defined in section 2.02.

Product Code	Product Description	Product Length	Unit
H3-001T-1000	Handrail Strip 16mm, with foam Tape	1000mm	each
H3-001T-3060	Handrail Strip 16mm, with foam Tape, FULL LENGTH	3060mm	each
HREC3	Metal End Cap for H3 Handrail Strip	NA	each
H5-001T-1000	Handrail Strip 27mm, with foam Tape	1000mm	each
H5-001T-3060	Handrail Strip 27mm, with foam Tape, FULL LENGTH	3060mm	each
HEC5	Plastic End Cap for H5 Handrail Strip	NA	each

Flat Handrails

Guidance Strip for marking flat handrails consisting of materials and manufactured using processes as defined in section 2.02.

Product Code	Product Name	Product Length	Unit
G3-001T-1000	Guidance Strip – 16mm, with foam Tape	1000mm	each
G3-001T-3060	Guidance Strip – 16m, with foam Tape, FULL LENGTH	3060mm	each
G6-003T-1000	Guidance Strip 26mm, with foam Tape	1000mm	each
G6-003T-3060	Guidance Strip 26mm, with foam Tape, FULL LENGTH	3060mm	each

d. Perimeter Demarcation Lines

Guidance strips and path markers for path marking on stair landings, corridors and other floor areas within all interior and exterior exit stairways, interior and exterior exit ramps and exit passageways consisting of materials and manufactured using processes as defined in section 2.02.

Product Code	Product Description	Product Length	Unit
G3-001-1000	Guidance Strip – 16mm	1000mm	each
G3-001-3060	Guidance Strip – 16mm, FULL LENGTH	3060mm	each
G3-001P-1000	Guidance Strip – 16mm, Punched	1000mm	each
G3-001P-3060	Guidance Strip – 16mm, Punched, FULL LENGTH	3060mm	each
G3-001T-1000	Guidance Strip – 16mm, with foam Tape	1000mm	each
G3-001T-3060	Guidance Strip – 16mm, with foam Tape, FULL LENGTH	3060mm	each
G6-003-1000	Guidance Strip – 26mm	1000mm	each
G6-003-3060	Guidance Strip – 26mm, FULL LENGTH	3060mm	each
G6-003P-1000	Guidance Strip – 26mm, Punched	1000mm	each
G6-003P-3060	Guidance Strip – 26mm, Punched, FULL LENGTH	3060mm	each
G6-003T-1000	Guidance Strip – 26mm, with foam Tape	1000mm	each
G6-003T-3060	Guidance Strip – 26mm, with foam Tape, FULL LENGTH	3060mm	each
T6-101-1000	Path Marker – 37mm	1000mm	each
T6-101P-1000	Path Marker – 37mm, Punched	1000mm	each
T5-101-1000	Path Marker – 51mm	1000mm	each
T5-101P-1000	Path Marker – 51mm, Punched	1000mm	each

e. Obstacles

Hazard Marking Tape* for outlining obstacles projecting into the egress path. Manufactured from high quality vinyl.

*Non-HTC products due to irregular shape of obstacles.

Product Code	Product Description	Product Length	Unit
UL-HZ2503	Hazard Tape – 25mm	3 metre roll	each
UL-HZ2518	Hazard Tape – 25mm	18 metre roll	each

f. Doors

(i) Emergency Exit Symbol

Directional Sign for identifying doors leading to an emergency exit consisting of materials and manufactured using processes as defined in section 2.02 (iii).

Product Code	Product Description	Product Size	Unit
S5-RMR1010	Directional Pictogram - Right Facing	100mm x 100mm	each
S5-RML1010	Directional Pictogram - Left Facing	100mm x 100mm	each
S5-ARS1010	Directional Arrow - Straight	100mm x 100mm	each
S5-ARD1010	Directional Arrow - Diagonal	100mm x 100mm	each

(ii) Door Hardware Markings

Door Handle Marker consisting of materials and manufactured using processes as defined in section 2.02 (iii).

EXCEPTION: For rounded push bars non-HTC products may be used and may consist of high quality vinyl.

Product Code	Product Description	Product Size	Unit
S5-DHM1010	Door Handle Marker	100mm x 100mm	each
UL-DHM3840*	Door Push Bar Marker	38mm x 407mm	each

(iii) Door Frame Markings

Guidance Strip for marking flat handrails consisting of materials and manufactured using processes as defined in section 2.02.

Product Code	Product Description	Product Length	Unit
G3-001-1000	Guidance Strip – 16mm	1000mm	each
G3-001-3060	Guidance Strip – 16mm, FULL LENGTH	3060mm	each
G3-001P-1000	Guidance Strip – 16mm, Punched	1000mm	each
G3-001P-3060	Guidance Strip – 16mm, Punched, FULL LENGTH	3060mm	each
G3-001T-1000	Guidance Strip – 16mm, with foam Tape	1000mm	each
G3-001T-3060	Guidance Strip – 16mm, with foam Tape, FULL LENGTH	3060mm	each
G6-003-1000	Guidance Strip – 26mm	1000mm	each
G6-003-3060	Guidance Strip – 26mm, FULL LENGTH	3060mm	each
G6-003P-1000	Guidance Strip – 26mm, Punched	1000mm	each
G6-003P-3060	Guidance Strip – 26mm, Punched, FULL LENGTH	3060mm	each
G6-003T-1000	Guidance Strip – 26mm, with foam Tape	1000mm	each
G6-003T-3060	Guidance Strip – 26mm, with foam Tape, FULL LENGTH	3060mm	each

2.04 Performance Criteria

All HTC products to meet or exceed the performance criteria specified in the following tests or standards. PC = Performance Criteria.

a. Slip Resistance

UL 410 Standard for Slip Resistance of Floor Surface Materials.

PC – Pass.

b. UV Resistance

ASTM G155-04 Cycle 1 1000hrs, Standard Practice for Operating Xenon Arc Light Apparatus for Exposure of Nonmetallic Materials.

PC – Loss in luminance after exposure < 10%

c. Salt Spray Resistance

ASTM B117-97 1000hrs, Standard Practice for Operating Salt Spray (Fog) Apparatus.
PC – Slight corrosion build up along scribes, no blistering or filiform growth along scribes.

d. Washability

ASTM D4828-94(2003), Standard Test Methods for Practical Washability of Organic Coatings.
PC – crayon, pen, 3M soil: all rating 10, being complete removal of soilant.

e. Rate of Burning

ASTM D635-03, Standard Test Method for Rate of Burning and/or Extent and Time of Burning of Plastics in a Horizontal Position.
PC – Time of burn 0 seconds, does not burn.

f. Surface Flammability

ASTM E162-02, Standard Test Method for Surface Flammability of Materials Using a Radiant Heat Energy Source.
PC – Flame spread index 7.6, ignites with difficulty.

g. Toxicity

Bombardier Toxic Gas Generation Test SMP800-C.
PC - Pass

h. Radioactivity

ASTM D3648-2004, Standard Practices for the Measurement of Radioactivity.
PC – Pass

i. Luminance

UL 1994 Standard for Luminous Egress Path Marking Systems.
PC – Pass

j. High Temperature Curing

Independently tested by exposing representative samples to 150°C in an oven for 20 minutes, then assessing in accordance with the relevant parts of AS/NZS 1580.481 for colour change, blistering, and distortion/shrinkage.
PC - There shall be no colour change, blistering, or distortion/shrinkage.

Part 3 CONSTRUCTION REQUIREMENTS

3.01 Manufacturer's Instructions

Comply with manufacturer's product data, installation instructions and maintenance and cleaning instructions. See Appendices 1, 2 and 6.

3.02 Examination

Site verification of conditions is required to verify installation surface and appropriate installation method.

3.03 Installation

Installation must be as per manufacturer's installation instructions. See Appendix 2.

3.05 Cleaning

Maintenance and cleaning should be carried out as per manufacturer's maintenance and cleaning instructions. See Appendix 6.

Part 4 METHOD OF MEASUREMENT

4.01 Accepted Quantity of Products

Egress path marking products shall be measured by the standard unit, or part thereof, to determine the accepted quantity.

Part 5 BASIS OF PAYMENT

5.01 Contract Unit Price

The accepted quantities, as determined in Part 4 Method of Measurement, shall be paid at the contract unit prices (including full contract unit price of units from which custom lengths are cut) plus any % loading for customisation of lengths.

Appendices to

Ecoglo International Ltd

Technical Manual

for

Photoluminescent Egress Path Markings



Contents:

Appendix 1 – Product Data Sheets	30
Appendix 2 – Installation Instructions	57
Appendix 3 – Product Test Reports	94
Appendix 4 – Quality Assurance Document	145
Appendix 5 – Warranty	147
Appendix 6 – Maintenance and Cleaning Instructions	150

Appendix 1

Ecoglo International Ltd

Product Data Sheets

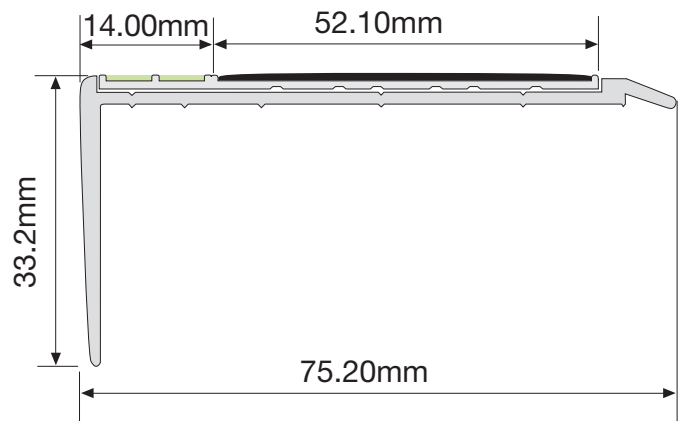
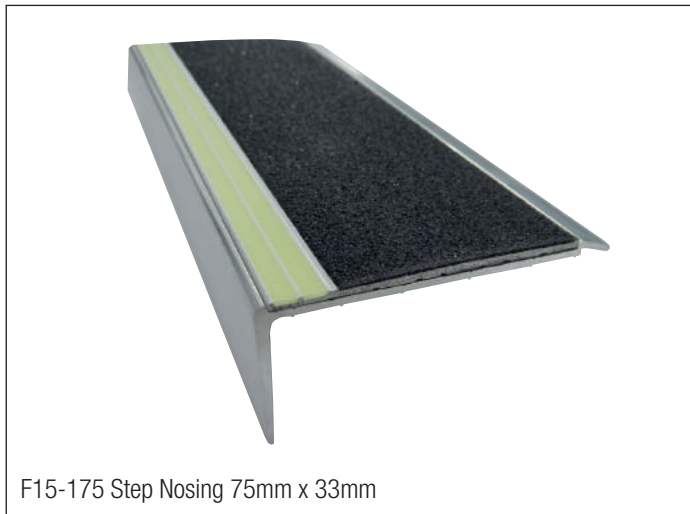

The F15-175 Step Nosing is designed to ensure visibility of steps in escape routes for compliance with International Fire Code (IFC), and any performance based building codes. The Step Nosing will be effective in all light conditions including during failure of the main lighting.

COMPLIANCE

Tested to UL 1994 specifications to meet IFC. This product has also been independently tested for use in Performance Solutions to meet the performance requirements of any performance based building codes.

The Step Nosing is suitable for use indoors and outdoors. The anti-slip material provides all weather protection from slips and falls.

Anti-slip Properties – UL410 Standard for Slip Resistance for Floor Surface Materials

AS/NZS 4586-2004 Classification: Dry: F Wet: V Ramp: R12

AS 4586-2013 Classification: P5

UV Resistance - Loss of luminance after 1000 hrs ASTM G-155
Cycle 1 exposure: <10%

Salt Spray Resistance – ASTM B117: Pass

Washability – ASTM D4828: Pass

Rate of Burning – ASTM D635: Pass

Surface Flammability - ASTM E162: Pass

Toxicity - Bombardier Toxic Gas Generation Test SMP800-C: Pass

Radioactivity - ASTM D3648: Pass

SUPPLY

The products are available in 100mm increments from 800mm to 1500mm to comply with IBC recommendations to mark the escape path on the front edge of the step to within 50mm of the wall or the side of the step. Custom lengths can also be fabricated on site from 2.45 metre and 3.06 metre lengths.

COMPOSITION

The F15-175 Step Nosing profile consists of 6060T5 aluminium extrusion, anodized (natural/silver colour) to 20 microns thickness.

Ecoglo E14-075 Step Edge Contrast is adhesively fixed into the extrusion. The high visibility E14-075 is manufactured from extruded 6063T5

aluminium section. Silicon Carbide anti-slip materials and custom made photoluminescent pigment are embedded in thermoset polyester carriers to integrally bond the active ingredients into the aluminium following curing at high temperature. The photoluminescent area is also recessed into protective channels.



INSTALLATION

The F15-175 Step Nosing can be used on a range of substrates including concrete, timber, tiles, vinyl, steel and checker plate. Uni clamp assemblies can be used for installation onto steel mesh steps.

It can also be fitted over steps with an industrial or commercial style carpet with no underlay. For thicker carpet, cut the carpet away and use a packer.

Installation is a simple process using fixers (supplied) and polyurethane adhesive.

Maximum recommended length for outdoor installation is 1500mm.

Consult Installation Instructions on website for full details and surface preparation.

PRODUCT CODE	PRODUCT DESCRIPTION	PRODUCT LENGTH
F15-175-800	Step Nosing 75mm x 33mm	800mm
F15-175-900	Step Nosing 75mm x 33mm	900mm
F15-175-1000	Step Nosing 75mm x 33mm	1000mm
F15-175-1100	Step Nosing 75mm x 33mm	1100mm
F15-175-1200	Step Nosing 75mm x 33mm	1200mm
F15-175-1300	Step Nosing 75mm x 33mm	1300mm
F15-175-1400	Step Nosing 75mm x 33mm	1400mm
F15-175-1500	Step Nosing 75mm x 33mm	1500mm

Contact

Ecoglo International Limited

Email: info@ecoglo.com **Web:** www.ecoglo.com

Product Data Sheet - Step Nosing F14-175

2020 V1

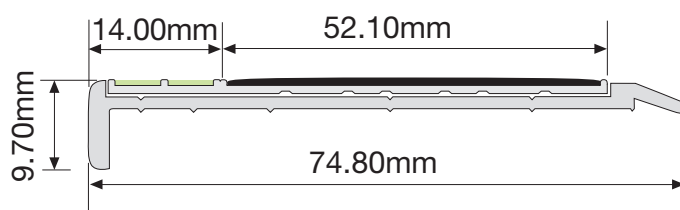
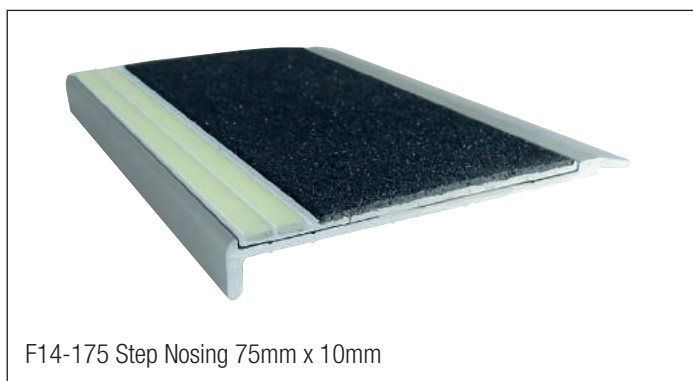

The F14-175 Step Nosing is designed to ensure visibility of steps in escape routes for compliance with International Fire Code (IFC), and any performance based building codes. The Step Nosing will be effective in all light conditions including during failure of the main lighting.

COMPLIANCE

Tested to UL 1994 specifications to meet IFC. This product has also been independently tested for use in Performance Solutions to meet the performance requirements of any performance based building codes.

The Step Nosing is suitable for use indoors and outdoors. The anti-slip material provides all weather protection from slips and falls.

Anti-slip Properties – UL410 Standard for Slip Resistance for Floor Surface Materials

AS/NZS 4586-2004 Classification: Dry: F Wet: V Ramp: R12

AS 4586-2013 Classification: P5

UV Resistance - Loss of luminance after 1000 hrs ASTM G-155 Cycle 1 exposure: <10%

Salt Spray Resistance – ASTM B117: Pass

Washability – ASTM D4828: Pass

Rate of Burning – ASTM D635: Pass

Surface Flammability - ASTM E162: Pass

Toxicity - Bombardier Toxic Gas Generation Test SMP800-C: Pass

Radioactivity - ASTM D3648: Pass

SUPPLY

The products are available in 100mm increments from 800mm to 1500mm to comply with IBC recommendations to mark the escape path on the front edge of the step to within 50mm of the wall or the side of the step. Custom lengths can also be fabricated on site from 2.45 metre and 3.06 metre lengths.

COMPOSITION

The F14-175 Step Nosing profile consists of 6060T5 aluminium extrusion, anodized (natural/silver colour) to 20 microns thickness.

Ecoglo E14-075 Step Edge Contrast is adhesively fixed into the extrusion. The high visibility E14-075 is manufactured from extruded 6063T5 aluminium section. Silicon Carbide anti-slip materials and custom made photoluminescent pigment are embedded in thermoset polyester carriers to integrally bond the active ingredients into the aluminium following cur-

ing at high temperature. The photoluminescent area is also recessed into protective channels.



INSTALLATION

The F14-175 Step Nosing can be used on a range of substrates including concrete, timber, tiles, vinyl, steel and checker plate. Uni clamp assemblies can be used for installation onto steel mesh steps.

It can also be fitted over steps with an industrial or commercial style carpet with no underlay. For thicker carpet, cut the carpet away and use a packer.

Installation is a simple process using fixers (supplied) and polyurethane adhesive.

Maximum recommended length for outdoor installation is 1500mm.

Consult Installation Instructions on website for full details and surface preparation.

PRODUCT CODE	PRODUCT DESCRIPTION	PRODUCT LENGTH
F14-175-800	Step Nosing 75mm x 10mm	800mm
F14-175-900	Step Nosing 75mm x 10mm	900mm
F14-175-1000	Step Nosing 75mm x 10mm	1000mm
F14-175-1100	Step Nosing 75mm x 10mm	1100mm
F14-175-1200	Step Nosing 75mm x 10mm	1200mm
F14-175-1300	Step Nosing 75mm x 10mm	1300mm
F14-175-1400	Step Nosing 75mm x 10mm	1400mm
F14-175-1500	Step Nosing 75mm x 10mm	1500mm

Contact

Ecoglo International Limited

Email: info@ecoglo.com Web: www.ecoglo.com

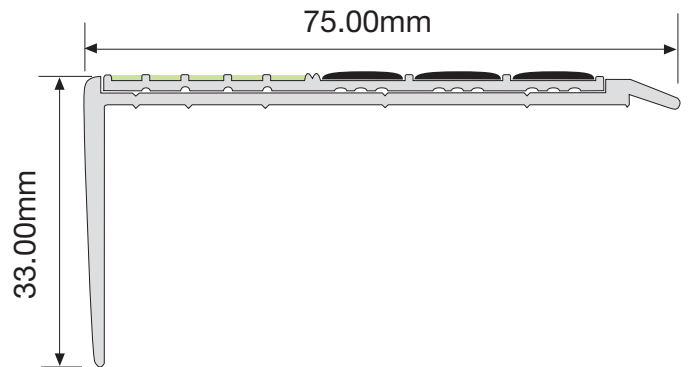
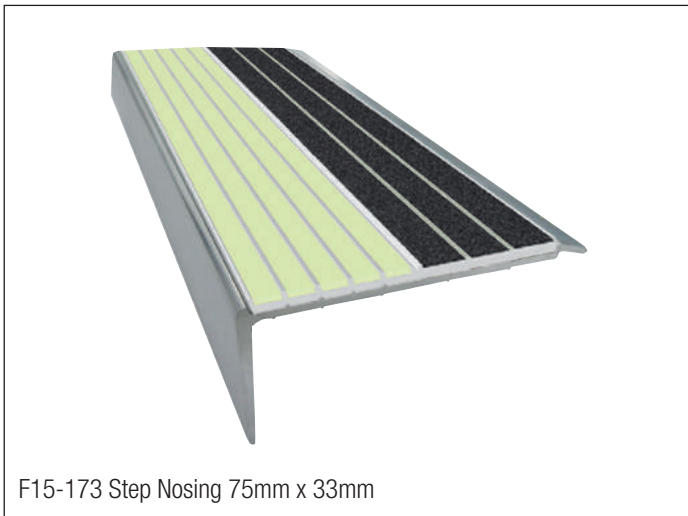

The F15-173 Step Nosing is designed to ensure visibility of steps in escape routes for compliance with NFPA Life Safety Code (NFPA 101) and International Fire Code (IFC), and any performance based building codes. The Step Nosing will be effective in all light conditions including during failure of the main lighting.

COMPLIANCE

Tested to UL 1994 specifications to meet the requirements of NFPA 101 and IFC. This product has also been independently tested for use in Performance Solutions to meet the performance requirements of any performance based building codes.

The Step Nosing is suitable for use indoors and outdoors. The anti-slip material provides all weather protection from slips and falls.

Anti-slip Properties – UL410 Standard for Slip Resistance for Floor Surface Materials

AS/NZS 4586-2004 Classification: Dry: F Wet: V Ramp: R12

AS 4586-2013 Classification: P5

UV Resistance - Loss of luminance after 1000 hrs ASTM G-155

Cycle 1 exposure: <10%

Salt Spray Resistance – ASTM B117: Pass

Washability – ASTM D4828: Pass

Rate of Burning – ASTM D635: Pass

Surface Flammability - ASTM E162: Pass

Toxicity - Bombardier Toxic Gas Generation Test SMP800-C: Pass

Radioactivity - ASTM D3648: Pass

SUPPLY

The products are available in 100mm increments from 800mm to 1500mm to comply with IBC recommendations to mark the escape path on the front edge of the step to within 50mm of the wall or the side of the step. Custom lengths can also be fabricated on site from 2.45 metre and 3.06 metre lengths.

COMPOSITION

The F15-173 Step Nosing profile consists of 6060T5 aluminium extrusion, anodized (natural/silver colour) to 20 microns thickness.

Ecoglo E15-073 Step Edge Contrast is adhesively fixed into the extrusion. The high visibility E15-073 is manufactured from extruded 6063T5 aluminium section. Silicon Carbide anti-slip materials and custom made photoluminescent pigment are embedded in thermoset polyester carriers to integrally bond the active ingredients into the aluminium following curing at high temperature. The photoluminescent area is also recessed into protective channels.



INSTALLATION

The F15-173 Step Nosing can be used on a range of substrates including concrete, timber, tiles, vinyl, steel and checker plate. Uni clamp assemblies can be used for installation onto steel mesh steps. It can also be fitted over steps with an industrial or commercial style carpet with no underlay. For thicker carpet, cut the carpet away and use a packer.

Installation is a simple process using fixers (supplied) and polyurethane adhesive.

Maximum recommended length for outdoor installation is 1500mm.

Consult Installation Instructions on website for full details and surface preparation.

PRODUCT CODE	PRODUCT DESCRIPTION	PRODUCT LENGTH
F15-173-800	Step Nosing 75mm x 33mm	800mm
F15-173-900	Step Nosing 75mm x 33mm	900mm
F15-173-1000	Step Nosing 75mm x 33mm	1000mm
F15-173-1100	Step Nosing 75mm x 33mm	1100mm
F15-173-1200	Step Nosing 75mm x 33mm	1200mm
F15-173-1300	Step Nosing 75mm x 33mm	1300mm
F15-173-1400	Step Nosing 75mm x 33mm	1400mm
F15-173-1500	Step Nosing 75mm x 33mm	1500mm

Contact

Ecoglo International Limited

Email: info@ecoglo.com Web: www.ecoglo.com

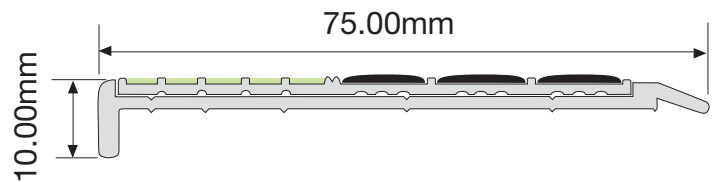
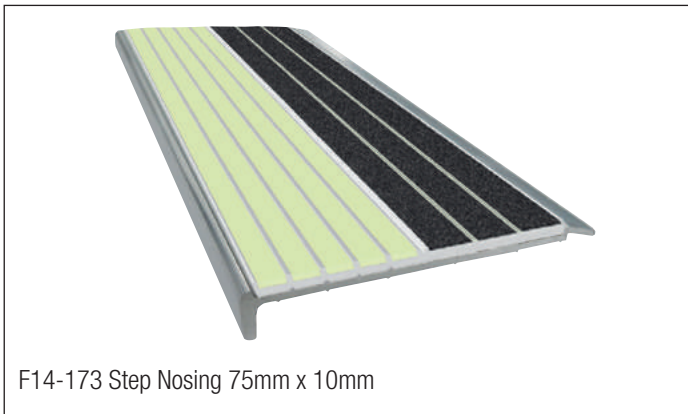

The F14-173 Step Nosing is designed to ensure visibility of steps in escape routes for compliance with NFPA Life Safety Code (NFPA) and International Fire Code (IFC), and any performance based building codes. The Step Nosing will be effective in all light conditions including during failure of the main lighting.

COMPLIANCE

Tested to UL 1994 specifications to meet the requirements of NFPA 101 and IFC. This product has also been independently tested for use in Performance Solutions to meet the performance requirements of any performance based building codes.

The Step Nosing is suitable for use indoors and outdoors. The anti-slip material provides all weather protection from slips and falls.

Anti-slip Properties – UL410 Standard for Slip Resistance for Floor Surface Materials

AS/NZS 4586-2004 Classification: Dry: F Wet: V Ramp: R12

AS 4586-2013 Classification: P5

UV Resistance - Loss of luminance after 1000 hrs ASTM G-155

Cycle 1 exposure: <10%

Salt Spray Resistance – ASTM B117: Pass

Washability – ASTM D4828: Pass

Rate of Burning – ASTM D635: Pass

Surface Flammability - ASTM E162: Pass

Toxicity - Bombardier Toxic Gas Generation Test SMP800-C: Pass

Radioactivity - ASTM D3648: Pass

SUPPLY

The products are available in 100mm increments from 800mm to 1500mm to comply with IBC recommendations to mark the escape path on the front edge of the step to within 50mm of the wall or the side of the step. Custom lengths can also be fabricated on site from 2.45 metre and 3.06 metre lengths.

COMPOSITION

The F14-173 Step Nosing profile consists of 6060T5 aluminium extrusion, anodized (natural/silver colour) to 20 microns thickness.

Ecoglo E15-073 Step Edge Contrast is adhesively fixed into the extrusion. The high visibility E15-073 is manufactured from extruded 6063T5

aluminium section. Silicon Carbide anti-slip materials and custom made photoluminescent pigment are embedded in thermoset polyester carriers to integrally bond the active ingredients into the aluminium following curing at high temperature. The photoluminescent area is also recessed into protective channels.



INSTALLATION

The F14-173 Step Nosing can be used on a range of substrates including concrete, timber, tiles, vinyl, steel and checker plate. Uni clamp assemblies can be used for installation onto steel mesh steps.

It can also be fitted over steps with an industrial or commercial style carpet with no underlay. For thicker carpet, cut the carpet away and use a packer.

Installation is a simple process using fixers (supplied) and polyurethane adhesive.

Maximum recommended length for outdoor installation is 1500mm.

Consult Installation Instructions on website for full details and surface preparation.

PRODUCT CODE	PRODUCT DESCRIPTION	PRODUCT LENGTH
F14-173-800	Step Nosing 75mm x 10mm	800mm
F14-173-900	Step Nosing 75mm x 10mm	900mm
F14-173-1000	Step Nosing 75mm x 10mm	1000mm
F14-173-1100	Step Nosing 75mm x 10mm	1100mm
F14-173-1200	Step Nosing 75mm x 10mm	1200mm
F14-173-1300	Step Nosing 75mm x 10mm	1300mm
F14-173-1400	Step Nosing 75mm x 10mm	1400mm
F14-173-1500	Step Nosing 75mm x 10mm	1500mm

Contact

Ecoglo International Limited

Email: info@ecoglo.com **Web:** www.ecoglo.com

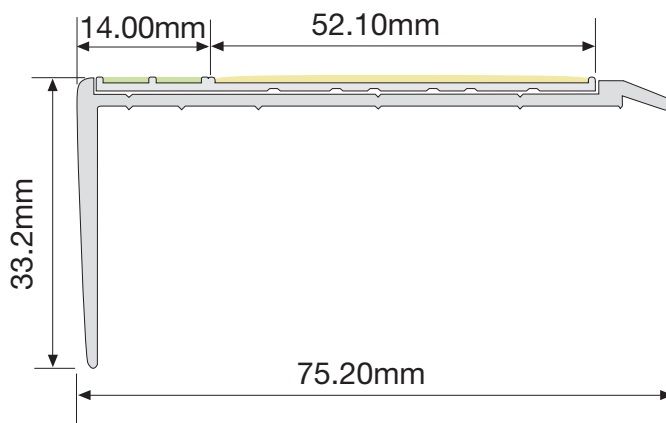
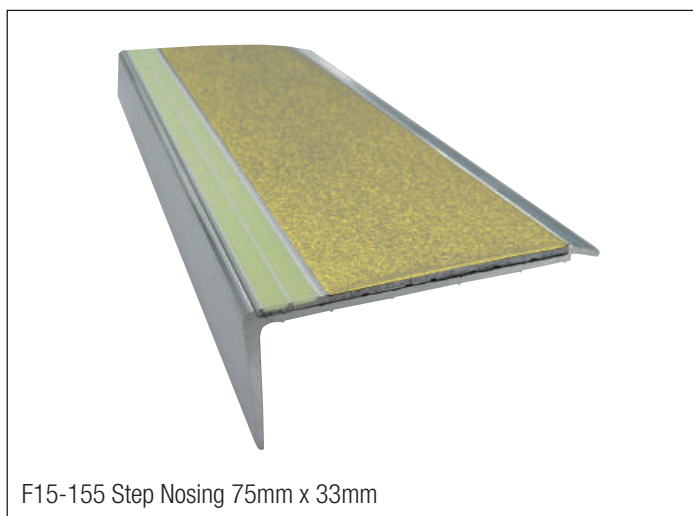

The F15-155 Step Nosing is designed to ensure visibility of steps in escape routes for compliance with International Fire Code (IFC), and any performance based building codes. The Step Nosing will be effective in all light conditions including during failure of the main lighting.

COMPLIANCE

Tested to UL 1994 specifications to meet IFC. This product has also been independently tested for use in Performance Solutions to meet the performance requirements of any performance based building codes.

The Step Nosing is suitable for use indoors and outdoors. The anti-slip material provides all weather protection from slips and falls.

Anti-slip Properties – UL410 Standard for Slip Resistance for Floor Surface Materials

AS/NZS 4586-2004 Classification: Dry: F Wet: V Ramp: R12

AS 4586-2013 Classification: P5

UV Resistance - Loss of luminance after 1000 hrs ASTM G-155

Cycle 1 exposure: <10%

Salt Spray Resistance – ASTM B117: Pass

Washability – ASTM D4828: Pass

Rate of Burning – ASTM D635: Pass

Surface Flammability - ASTM E162: Pass

Toxicity - Bombardier Toxic Gas Generation Test SMP800-C: Pass

Radioactivity - ASTM D3648: Pass

High Temperature Curing (HTC): Pass

SUPPLY

F15-155 is MADE TO ORDER in 100mm increments from 800mm to 1500mm to mark the escape path on the front edge of the step to within 50mm of the wall or the side of the step. Custom lengths can also be cut on site from 2.45 metre and 3.06 metre lengths.

COMPOSITION

The F15-155 Step Nosing profile consists of 6060T5 aluminium extrusion, anodized (natural/silver colour) to 20 microns thickness.

Ecoglo E14-055 Step Edge Contrast is adhesively fixed into the extrusion. The high visibility E14-055 is manufactured from extruded 6063T5

aluminium section. Silicon Carbide anti-slip materials and custom made photoluminescent pigment are embedded in thermoset polyester carriers to integrally bond the active ingredients into the aluminium following curing at high temperature. The photoluminescent area is also recessed into protective channels.



INSTALLATION

The F15-155 Step Nosing can be used on a range of substrates including concrete, timber, tiles, vinyl, steel and checker plate. Uni clamp assemblies can be used for installation onto steel mesh steps.

It can also be fitted over steps with an industrial or commercial style carpet with no underlay. For thicker carpet, cut the carpet away and use a packer.

Installation is a simple process using hidden fixers (supplied) and polyurethane adhesive. The nosing profile is pre-drilled in the recess. Once the insert is adhered into the recess the fixers are hidden.

On-site cutting from full lengths can be downloaded here:

[Major Projects with On Site Cutting](#)

Maximum recommended length for outdoor installation is 1500mm.

Consult Installation Instructions on website for full details and surface preparation.

PRODUCT CODE	PRODUCT DESCRIPTION	PRODUCT LENGTH
F15-155-800	Step Nosing 75mm x 33mm	800mm
F15-155-900	Step Nosing 75mm x 33mm	900mm
F15-155-1000	Step Nosing 75mm x 33mm	1000mm
F15-155-1100	Step Nosing 75mm x 33mm	1100mm
F15-155-1200	Step Nosing 75mm x 33mm	1200mm
F15-155-1300	Step Nosing 75mm x 33mm	1300mm
F15-155-1400	Step Nosing 75mm x 33mm	1400mm
F15-155-1500	Step Nosing 75mm x 33mm	1500mm

Contact

Ecoglo International Limited

Email: info@ecoglo.com **Web:** www.ecoglo.com

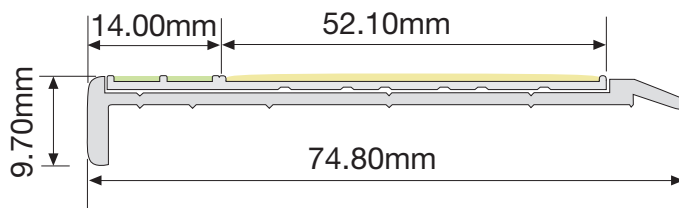
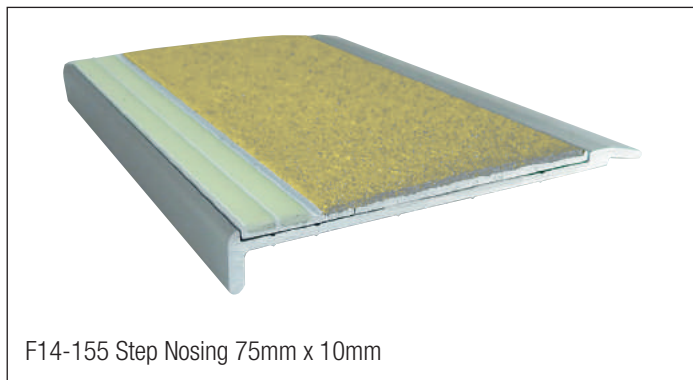

The F14-155 Step Nosing is designed to ensure visibility of steps in escape routes for compliance with International Fire Code (IFC), and any performance based building codes. The Step Nosing will be effective in all light conditions including during failure of the main lighting.

COMPLIANCE

Tested to UL 1994 specifications to meet IFC. This product has also been independently tested for use in Performance Solutions to meet the performance requirements of any performance based building codes.

The Step Nosing is suitable for use indoors and outdoors. The anti-slip material provides all weather protection from slips and falls.

Anti-slip Properties – UL410 Standard for Slip Resistance for Floor Surface Materials

AS/NZS 4586-2004 Classification: Dry: F Wet: V Ramp: R12

AS 4586-2013 Classification: P5

UV Resistance - Loss of luminance after 1000 hrs ASTM G-155 Cycle 1 exposure: <10%

Salt Spray Resistance – ASTM B117: Pass

Washability – ASTM D4828: Pass

Rate of Burning – ASTM D635: Pass

Surface Flammability - ASTM E162: Pass

Toxicity - Bombardier Toxic Gas Generation Test SMP800-C: Pass

Radioactivity - ASTM D3648: Pass

High Temperature Curing (HTC): Pass

SUPPLY

F14-155 is MADE TO ORDER in 100mm increments from 800mm to 1500mm to mark the escape path on the front edge of the step to within 50mm of the wall or the side of the step. Custom lengths can also be cut on site from 2.45 metre and 3.06 metre lengths.

COMPOSITION

The F14-155 Step Nosing profile consists of 6060T5 aluminium extrusion, anodized (natural/silver colour) to 20 microns thickness.

Ecoglo E14-055 Step Edge Contrast is adhesively fixed into the extrusion. The high visibility E14-055 is manufactured from extruded 6063T5 aluminium section. Silicon Carbide anti-slip materials and custom made photoluminescent pigment are embedded in thermoset polyester carriers to integrally bond the active ingredients into the aluminium following curing at high temperature. The photoluminescent area is also recessed into protective channels.

ing at high temperature. The photoluminescent area is also recessed into protective channels.



INSTALLATION

The F14-155 Step Nosing can be used on a range of substrates including concrete, timber, tiles, vinyl, steel and checker plate. Uni clamp assemblies can be used for installation onto steel mesh steps.

It can also be fitted over steps with an industrial or commercial style carpet with no underlay. For thicker carpet, cut the carpet away and use a packer.

Installation is a simple process using hidden fixers (supplied) and polyurethane adhesive. The nosing profile is pre-drilled in the recess. Once the insert is adhered into the recess the fixers are hidden.

On-site cutting from full lengths can be downloaded here:

[Major Projects with On Site Cutting](#)

Maximum recommended length for outdoor installation is 1500mm.

Consult Installation Instructions on website for full details and surface preparation.

PRODUCT CODE	PRODUCT DESCRIPTION	PRODUCT LENGTH
F14-155-800	Step Nosing 75mm x 10mm	800mm
F14-155-900	Step Nosing 75mm x 10mm	900mm
F14-155-1000	Step Nosing 75mm x 10mm	1000mm
F14-155-1100	Step Nosing 75mm x 10mm	1100mm
F14-155-1200	Step Nosing 75mm x 10mm	1200mm
F14-155-1300	Step Nosing 75mm x 10mm	1300mm
F14-155-1400	Step Nosing 75mm x 10mm	1400mm
F14-155-1500	Step Nosing 75mm x 10mm	1500mm

Contact

Ecoglo International Limited

Email: info@ecoglo.com Web: www.ecoglo.com

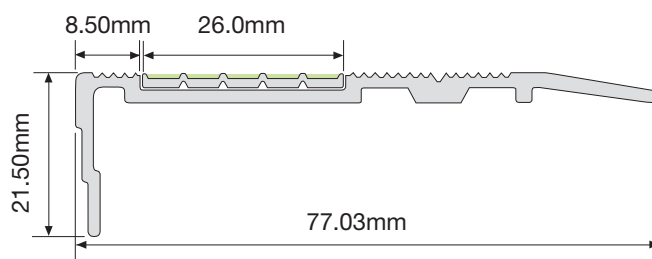
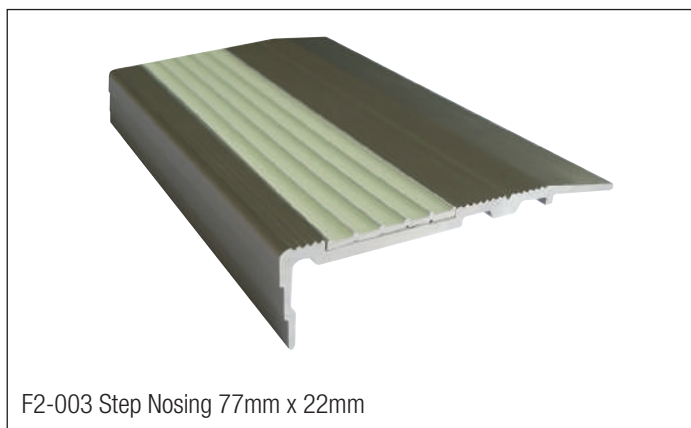

The F2-003 Step Nosing is designed to ensure visibility of steps in escape routes for compliance with NFPA 101 Life Safety Code (NFPA 101) and International Fire Code (IFC). The Step Nosing will be effective in all light conditions including during failure of the main lighting.

COMPLIANCE

Tested to UL 1994 specifications to meet the requirements of NFPA 101 and IFC. This product has also been independently tested for use in Performance Solutions to meet the performance requirements of any performance based building codes.

The Step Nosing is suitable for use indoors and outdoors.

UV Resistance - Loss of luminance after 1000 hrs ASTM G-155

Cycle 1 exposure: <10%

Salt Spray Resistance – ASTM B117: Pass

Washability – ASTM D4828: Pass

Rate of Burning – ASTM D635: Pass

Surface Flammability - ASTM E162: Pass

Toxicity - Bombardier Toxic Gas Generation Test SMP800-C: Pass

Radioactivity - ASTM D3648: Pass

SUPPLY

The products are available in 100mm increments from 800mm to 1500mm to comply with IBC recommendations to mark the escape path on the front edge of the step to within 50mm of the wall or the side of the step.

COMPOSITION

The F2-003 Step Nosing profile consists of 6060T5 mill finished aluminium extrusion.

Ecoglo G6-003 Guidance Strip is adhesively fixed into the extrusion. The high visibility G6-003 is manufactured from extruded 6063T5 aluminium section. Custom made photoluminescent pigments are embedded in thermoset polyester carriers to integrally bond the active ingredients into the aluminium following curing at high temperature. The photoluminescent area is also recessed into protective channels.

INSTALLATION

The F2-003 Step Nosing can be used on a range of substrates including concrete, timber, tiles, vinyl, steel and checker plate. Uni clamp assemblies can be used for installation onto steel mesh steps.

Installation is a simple process using fixers (supplied) and polyurethane adhesive. It can also be fitted over steps with an industrial or commercial style carpet with no underlay. For thicker carpet, cut the carpet away and use a packer.

Maximum recommended length for outdoor installation is 1500mm.

Consult Installation Instructions on website for full details and surface preparation.

PRODUCT CODE	PRODUCT DESCRIPTION	PRODUCT LENGTH
F2-003-800	Step Nosing 77mm x 22mm	800mm
F2-003-900	Step Nosing 77mm x 22mm	900mm
F2-003-1000	Step Nosing 77mm x 22mm	1000mm
F2-003-1100	Step Nosing 77mm x 22mm	1100mm
F2-003-1200	Step Nosing 77mm x 22mm	1200mm
F2-003-1300	Step Nosing 77mm x 22mm	1300mm
F2-003-1400	Step Nosing 77mm x 22mm	1400mm
F2-003-1500	Step Nosing 77mm x 22mm	1500mm



Contact

Ecoglo International Limited

Email: info@ecoglo.com Web: www.ecoglo.com

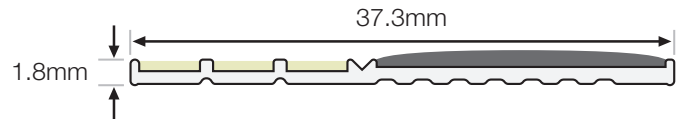

The E2-071 Step Edge Contrast is designed to ensure visibility of steps in escape routes for compliance with International Fire Code (IFC), and any performance based building codes. The Step Edge Contrast will be effective in all light conditions including during failure of the main lighting.

COMPLIANCE

Tested to UL 1994 specifications to meet IFC. This product has also been independently tested for use in Performance Solutions to meet the performance requirements of any performance based building codes.

The Step Edge Contrast is suitable for use indoors and outdoors. The anti-slip material provides all weather protection from slips and falls.

Anti-slip Properties – UL410 Standard for Slip Resistance for Floor Surface Materials

AS/NZS 4586-2004 Classification: Dry: F Wet: V Ramp: R12

AS 4586-2013 Classification: P5

UV Resistance - Loss of luminance after 1000 hrs ASTM G-155 Cycle 1 exposure: <10%

Salt Spray Resistance – ASTM B117: Pass

Washability – ASTM D4828: Pass

Rate of Burning – ASTM D635: Pass

Surface Flammability - ASTM E162: Pass

Toxicity - Bombardier Toxic Gas Generation Test SMP800-C: Pass

Radioactivity - ASTM D3648: Pass

SUPPLY

The products are available in 100mm increments from 800mm to 1500mm to comply with IBC recommendations to mark the escape path on the front edge of the step to within 50mm of the wall or the side of the step. Custom lengths can also be fabricated on site from 2.45 and 3.06 metre lengths.

COMPOSITION

Ecoglo E2-071 Step Edge Contrast is manufactured from extruded 60605T aluminium section. Silicon Carbide anti-slip materials and custom made photoluminescent pigment are embedded in thermoset polyester carriers to integrally bond the active ingredients into the aluminium following curing at high temperature. The photoluminescent area is also recessed into protective channels.



INSTALLATION

Indoors the E2-071 Step Edge Contrast can be surface mounted on all smooth surfaces. Outdoors the E2-071 Step Edge Contrast can be surface mounted onto concrete.

Installation is a simple process using polyurethane adhesive.

Maximum recommended length for outdoor installation is 1500mm.

Consult Installation Instructions on website for full details and surface preparation.

Screws can be used if adhesion is difficult.
(See order codes below for the product that best suits).

E2-071 For polyurethane adhesive fixing
E2-071P Punched for screw fixing

PRODUCT CODE	PRODUCT DESCRIPTION	PRODUCT LENGTH
E2-071-800	Step Edge Contrast 37mm	800mm
E2-071-900	Step Edge Contrast 37mm	900mm
E2-071-1000	Step Edge Contrast 37mm	1000mm
E2-071-1100	Step Edge Contrast 37mm	1100mm
E2-071-1200	Step Edge Contrast 37mm	1200mm
E2-071-1300	Step Edge Contrast 37mm	1300mm
E2-071-1400	Step Edge Contrast 37mm	1400mm
E2-071-1500	Step Edge Contrast 37mm	1500mm

Contact

Ecoglo International Limited

Email: info@ecoglo.com Web: www.ecoglo.com

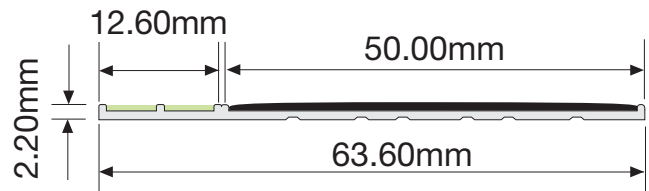
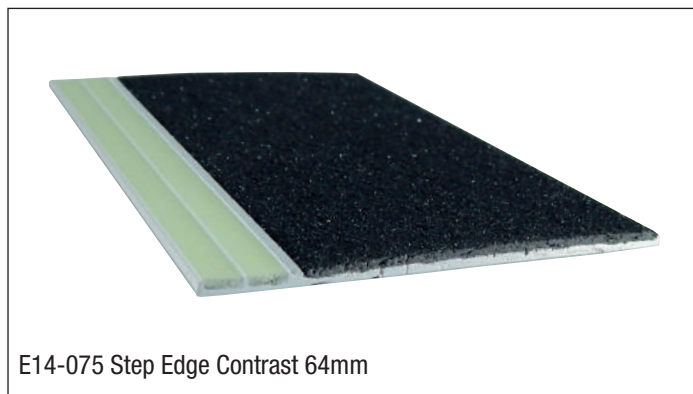

The E14-075 Step Edge Contrast is designed to ensure visibility of steps in escape routes for compliance with International Fire Code (IFC), and any performance based building codes. The Step Edge Contrast will be effective in all light conditions including during failure of the main lighting.

COMPLIANCE

Tested to UL 1994 specifications to meet IFC. This product has also been independently tested for use in Performance Solutions to meet the performance requirements of any performance based building codes.

The Step Edge Contrast is suitable for use indoors and outdoors. The anti-slip material provides all weather protection from slips and falls.

Anti-slip Properties – UL410 Standard for Slip Resistance for Floor Surface Materials

AS/NZS 4586-2004 Classification: Dry: F Wet: V Ramp: R12

AS 4586-2013 Classification: P5

UV Resistance - Loss of luminance after 1000 hrs ASTM G-155 Cycle 1 exposure: <10%

Salt Spray Resistance – ASTM B117: Pass

Washability – ASTM D4828: Pass

Rate of Burning – ASTM D635: Pass

Surface Flammability - ASTM E162: Pass

Toxicity - Bombardier Toxic Gas Generation Test SMP800-C: Pass

Radioactivity - ASTM D3648: Pass

SUPPLY

The products are available in 100mm increments from 800mm to 1500mm to comply with IBC recommendations to mark the escape path on the front edge of the step to within 50mm of the wall or the side of the step. Custom lengths can also be fabricated on site from 2.45 metre and 3.06 metre lengths.

COMPOSITION

Ecoglo E14-075 Step Edge Contrast is manufactured from extruded 60605T aluminium section. Silicon Carbide anti-slip materials and custom made photoluminescent pigment are embedded in thermoset polyester carriers to integrally bond the active ingredients into the aluminium following curing at high temperature. The photoluminescent area is also recessed into protective channels.



INSTALLATION

Indoors the E14-075 Step Edge Contrast can be surface mounted on all smooth surfaces. Outdoors the E14-075 Step Edge Contrast can be surface mounted onto concrete.

Installation is a simple process using polyurethane adhesive.

Maximum recommended length for outdoor installation is 1500mm.

Consult Installation Instructions on website for full details and surface preparation.

Screws can be used if adhesion is difficult.

(See order codes below for the product that best suits).

E14-075 For polyurethane adhesive fixing
E14-075P Punched for screw fixing

PRODUCT CODE	PRODUCT DESCRIPTION	PRODUCT LENGTH
E14-075-800	Step Edge Contrast 64mm	800mm
E14-075-900	Step Edge Contrast 64mm	900mm
E14-075-1000	Step Edge Contrast 64mm	1000mm
E14-075-1100	Step Edge Contrast 64mm	1100mm
E14-075-1200	Step Edge Contrast 64mm	1200mm
E14-075-1300	Step Edge Contrast 64mm	1300mm
E14-075-1400	Step Edge Contrast 64mm	1400mm
E14-075-1500	Step Edge Contrast 64mm	1500mm

Contact

Ecoglo International Limited

Email: info@ecoglo.com Web: www.ecoglo.com

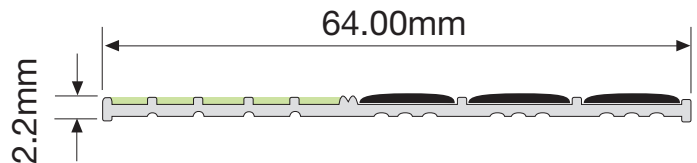
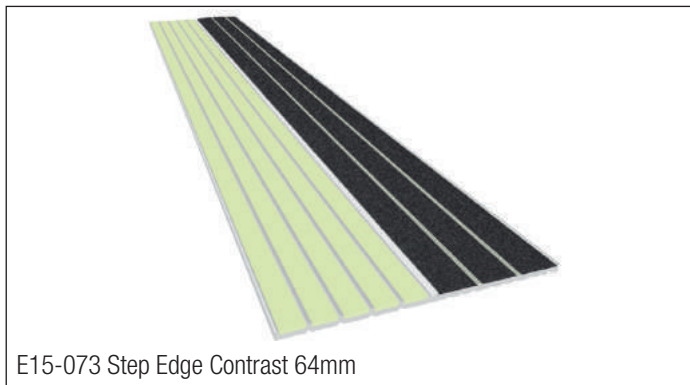

The E15-073 Step Edge Contrast is designed to ensure visibility of steps in escape routes for compliance with NFPA 101 Life Safety Code (NFPA 101) and International Fire Code (IFC). The Step Edge Contrast will be effective in all light conditions including during failure of the main lighting.

COMPLIANCE

Tested to UL 1994 specifications to meet the requirements of NFPA 101 and IFC. This product has also been independently tested for use in Performance Solutions to meet the performance requirements of any performance based building codes.

The Step Edge Contrast is suitable for use indoors and outdoors. The anti-slip material provides all weather protection from slips and falls.

Anti-slip Properties – UL410 Standard for Slip Resistance for Floor Surface Materials

AS/NZS 4586-2004 Classification: Dry: F Wet: V Ramp: R12

AS 4586-2013 Classification: P5

UV Resistance - Loss of luminance after 1000 hrs ASTM G-155 Cycle 1 exposure: <10%

Salt Spray Resistance – ASTM B117: Pass

Washability – ASTM D4828: Pass

Rate of Burning – ASTM D635: Pass

Surface Flammability - ASTM E162: Pass

Toxicity - Bombardier Toxic Gas Generation Test SMP800-C: Pass

Radioactivity - ASTM D3648: Pass

SUPPLY

The products are available in 100mm increments from 800mm to 1500mm to comply with IBC recommendations to mark the escape path on the front edge of the step to within 50mm of the wall or the side of the step. Custom lengths can also be fabricated on site from 2.45 metre and 3.06 metre lengths.

COMPOSITION

Ecoglo E15-073 Step Edge Contrast is manufactured from extruded 60605T aluminium section. Silicon Carbide anti-slip materials and custom made photoluminescent pigment are embedded in thermoset polyester carriers to integrally bond the active ingredients into the aluminium following curing at high temperature. The photoluminescent area is also recessed into protective channels.



INSTALLATION

Indoors the E15-073 Step Edge Contrast can be surface mounted on all smooth surfaces. Outdoors the E15-073 Step Edge Contrast can be surface mounted onto concrete.

Installation is a simple process using polyurethane adhesive.

Maximum recommended length for outdoor installation is 1500mm.

Consult Installation Instructions on website for full details and surface preparation.

Screws can be used if adhesion is difficult.

(See order codes below for the product that best suits).

E15-073 For polyurethane adhesive fixing
E15-073P Punched for screw fixing

PRODUCT CODE	PRODUCT DESCRIPTION	PRODUCT LENGTH
E15-073-800	Step Edge Contrast 51mm	800mm
E15-073-900	Step Edge Contrast 51mm	900mm
E15-073-1000	Step Edge Contrast 51mm	1000mm
E15-073-1100	Step Edge Contrast 51mm	1100mm
E15-073-1200	Step Edge Contrast 51mm	1200mm
E15-073-1300	Step Edge Contrast 51mm	1300mm
E15-073-1400	Step Edge Contrast 51mm	1400mm
E15-073-1500	Step Edge Contrast 51mm	1500mm

Contact

Ecoglo International Limited

Email: info@ecoglo.com Web: www.ecoglo.com

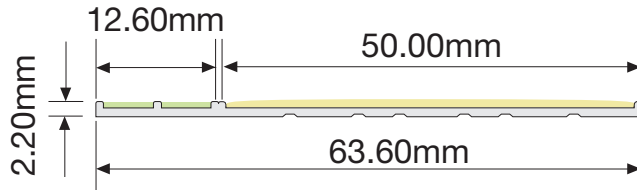
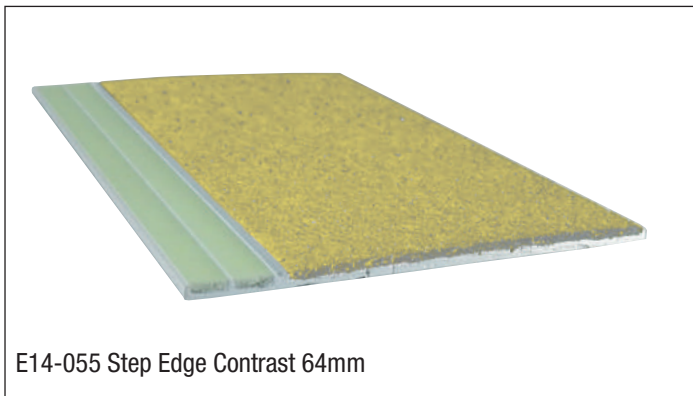

The E14-055 Step Edge Contrast is designed to ensure visibility of steps in escape routes for compliance with International Fire Code (IFC), and any performance based building codes. The Step Edge Contrast will be effective in all light conditions including during failure of the main lighting.

COMPLIANCE

Tested to UL 1994 specifications to meet IFC. This product has also been independently tested for use in Performance Solutions to meet the performance requirements of any performance based building codes.

The Step Edge Contrast is suitable for use indoors and outdoors. The anti-slip material provides all weather protection from slips and falls.

Anti-slip Properties – UL410 Standard for Slip Resistance for Floor Surface Materials

AS/NZS 4586-2004 Classification: Dry: F Wet: V Ramp: R12

AS 4586-2013 Classification: P5

UV Resistance - Loss of luminance after 1000 hrs ASTM G-155 Cycle 1 exposure: <10%

Salt Spray Resistance – ASTM B117: Pass

Washability – ASTM D4828: Pass

Rate of Burning – ASTM D635: Pass

Surface Flammability - ASTM E162: Pass

Toxicity - Bombardier Toxic Gas Generation Test SMP800-C: Pass

Radioactivity - ASTM D3648: Pass

High Temperature Curing (HTC): Pass

SUPPLY

E14-055 is MADE TO ORDER in 100mm increments from 800mm to 1500mm to mark the escape path on the front edge of the step to within 50mm of the wall or the side of the step. Custom lengths can also be cut on site from 2.45 metre and 3.06 metre lengths.

COMPOSITION

Ecoglo E14-055 Step Edge Contrast is manufactured from extruded 60635T aluminium section. Silicon Carbide anti-slip materials and custom made photoluminescent pigment are embedded in thermoset polyester carriers to integrally bond the active ingredients into the aluminium following curing at high temperature. The photoluminescent area is also recessed into protective channels.



INSTALLATION

Indoors the E14-055 Step Edge Contrast can be surface mounted on all smooth surfaces. Outdoors the E14-055 Step Edge Contrast can be surface mounted onto concrete.

Installation is a simple process using polyurethane adhesive. If adhesion is difficult screws can be used. On-site cutting from full lengths can be downloaded here: [Major Projects with On Site Cutting](#)

Maximum recommended length for outdoor installation is 1500mm.

Consult Installation Instructions on website for full details and surface preparation.

(See order codes below for the product that best suits).

E14-055 For polyurethane adhesive fixing
E14-055P Punched for screw fixing

PRODUCT CODE	PRODUCT DESCRIPTION	PRODUCT LENGTH
E14-055-800	Step Edge Contrast 64mm	800mm
E14-055-900	Step Edge Contrast 64mm	900mm
E14-055-1000	Step Edge Contrast 64mm	1000mm
E14-055-1100	Step Edge Contrast 64mm	1100mm
E14-055-1200	Step Edge Contrast 64mm	1200mm
E14-055-1300	Step Edge Contrast 64mm	1300mm
E14-055-1400	Step Edge Contrast 64mm	1400mm
E14-055-1500	Step Edge Contrast 64mm	1500mm

Contact

Ecoglo International Limited

Email: info@ecoglo.com Web: www.ecoglo.com

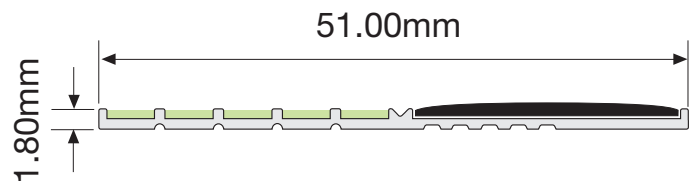
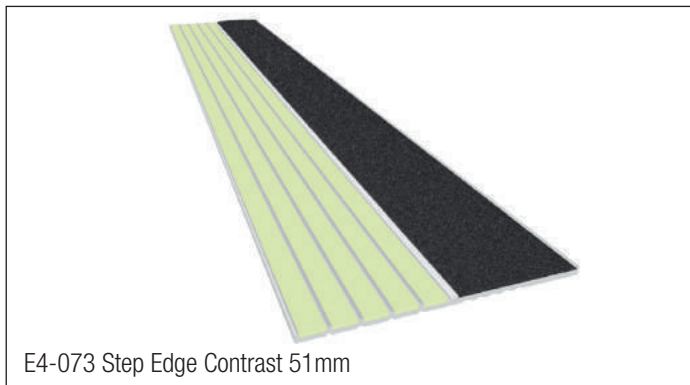

The E4-073 Step Edge Contrast is designed to ensure visibility of steps in escape routes for compliance with NFPA 101 Life Safety Code (NFPA 101) and International Fire Code (IFC). The Step Edge Contrast will be effective in all light conditions including during failure of the main lighting.

COMPLIANCE

Tested to UL 1994 specifications to meet the requirements of NFPA 101 and IFC. This product has also been independently tested for use in Performance Solutions to meet the performance requirements of any performance based building codes.

The Step Edge Contrast is suitable for use indoors and outdoors. The anti-slip material provides all weather protection from slips and falls.

Anti-slip Properties – UL410 Standard for Slip Resistance for Floor Surface Materials

AS/NZS 4586-2004 Classification: Dry: F Wet: V Ramp: R12

AS 4586-2013 Classification: P5

UV Resistance - Loss of luminance after 1000 hrs ASTM G-155 Cycle 1 exposure: <10%

Salt Spray Resistance – ASTM B117: Pass

Washability – ASTM D4828: Pass

Rate of Burning – ASTM D635: Pass

Surface Flammability - ASTM E162: Pass

Toxicity - Bombardier Toxic Gas Generation Test SMP800-C: Pass

Radioactivity - ASTM D3648: Pass

SUPPLY

The products are available in 100mm increments from 800mm to 1500mm to comply with IBC recommendations to mark the escape path on the front edge of the step to within 50mm of the wall or the side of the step. Custom lengths can also be fabricated on site from 2.45 metre and 3.06 metre lengths.

COMPOSITION

Ecoglo E4-073 Step Edge Contrast is manufactured from extruded 60605T aluminium section. Silicon Carbide anti-slip materials and custom made photoluminescent pigment are embedded in thermoset polyester carriers to integrally bond the active ingredients into the aluminium following curing at high temperature. The photoluminescent area is also recessed into protective channels.



INSTALLATION

Indoors the E4-073 Step Edge Contrast can be surface mounted on all smooth surfaces. Outdoors the E4-073 Step Edge Contrast can be surface mounted onto concrete.

Installation is a simple process using polyurethane adhesive.

Maximum recommended length for outdoor installation is 1500mm.

Consult Installation Instructions on website for full details and surface preparation.

Screws can be used if adhesion is difficult.

(See order codes below for the product that best suits).

E4-073 For polyurethane adhesive fixing
E4-073P Punched for screw fixing

PRODUCT CODE	PRODUCT DESCRIPTION	PRODUCT LENGTH
E4-073-800	Step Edge Contrast 51mm	800mm
E4-073-900	Step Edge Contrast 51mm	900mm
E4-073-1000	Step Edge Contrast 51mm	1000mm
E4-073-1100	Step Edge Contrast 51mm	1100mm
E4-073-1200	Step Edge Contrast 51mm	1200mm
E4-073-1300	Step Edge Contrast 51mm	1300mm
E4-073-1400	Step Edge Contrast 51mm	1400mm
E4-073-1500	Step Edge Contrast 51mm	1500mm

Contact

Ecoglo International Limited

Email: info@ecoglo.com Web: www.ecoglo.com



G6-003 Guidance Strip 26mm

The G6-003 Guidance Strip is designed to ensure visibility of specified building features in escape routes for compliance with NFPA 101 Life Safety Code (NFPA 101) and International Fire Code (IFC). The Guidance Strip will be effective in all light conditions including during failure of the main lighting.

COMPLIANCE

Tested to UL 1994 specifications to meet the requirements of NFPA 101 and IFC. This product has also been independently tested for use in Performance Solutions to meet the performance requirements of any performance based building codes.

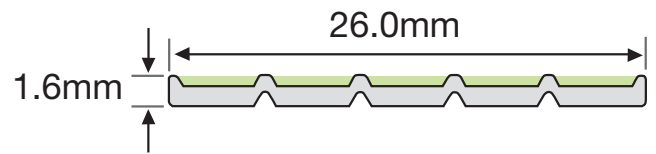

The Guidance Strip is suitable for use indoors and outdoors.

UV Resistance - Loss of luminance after 1000 hrs ASTM G-155

Cycle 1 exposure: <10%

Salt Spray Resistance – ASTM B117: Pass

Washability – ASTM D4828: Pass

Rate of Burning – ASTM D635: Pass

Surface Flammability - ASTM E162: Pass

Toxicity - Bombardier Toxic Gas Generation Test SMP800-C: Pass

Radioactivity - ASTM D3648: Pass

SUPPLY

The products are available in 1 metre lengths and 3.06 metre lengths.

COMPOSITION

Ecoglo G6-003 Guidance Strip is manufactured from extruded 6060T5 aluminium section. Custom made photoluminescent pigments are embedded in thermoset polyester carriers to integrally bond the active ingredients into the aluminium following curing at high temperature. The photoluminescent area is also recessed into protective channels.



INSTALLATION

Installation is a simple process using polyurethane adhesive, fixers (screws) or pre-fitted release tape.

Fixers (screws) can be used if adhesion is difficult.

(See order codes below for the product that best suits).

Consult Installation Instructions on website for full details and surface preparation.

G6-003-1000 For polyurethane adhesive fixing

G6-003-3060 For polyurethane adhesive fixing

G6-003P-1000 Punched for screw fixing

G6-003P-3060 Punched for screw fixing

G6-003T-1000 Release tape pre-fitted

G6-003T-3060 Release tape pre-fitted

Contact

Ecoglo International Limited

Email: info@ecoglo.com **Web:** www.ecoglo.com

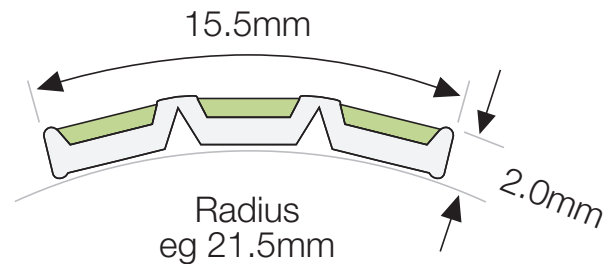
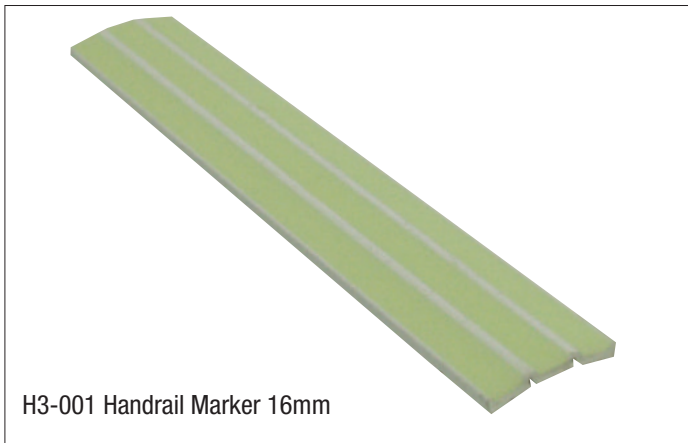

The H3-001 Handrail Marker is designed to ensure visibility of specified building features in escape routes for compliance with NFPA 101 Life Safety Code (NFPA 101) and International Fire Code (IFC), and any performance based building codes. The Handrail Marker will be effective in all light conditions including during failure of the main lighting.

COMPLIANCE

Tested to UL 1994 specifications to meet the requirements of NFPA 101 and IFC. This product has also been independently tested for use in Performance Solutions to meet the performance requirements of any performance based building codes.



The Handrail Marker is suitable for use indoors and outdoors.

- UV Resistance - Loss of luminance after 1000 hrs ASTM G-155 Cycle 1 exposure: <10%
- Salt Spray Resistance – ASTM B117: Pass
- Washability –ASTM D4828: Pass
- Rate of Burning – ASTM D635: Pass
- Surface Flammability - ASTM E162: Pass
- Toxicity - Bombardier Toxic Gas Generation Test SMP800-C: Pass
- Radioactivity - ASTM D3648: Pass

SUPPLY

The products are available in 1 metre and 3.06 metre lengths.

COMPOSITION

Ecoglo H3-001 Handrail Marker is manufactured from extruded 6060T5 aluminium section. Custom made photoluminescent pigments are embedded in thermoset polyester carriers to integrally bond the active ingredients into the aluminium following curing at high temperature. The photoluminescent area is also recessed into protective channels.



INSTALLATION

Installation is a simple process using pre-fitted release tape. Consult Installation Instructions on website for full details and surface preparation. Screws or rivets can be used if adhesion is difficult.

- H3-001T-1000** Release tape pre-fitted
- H3-001T-3060** Release tape pre-fitted

END CAPS

Metal end caps to fit H3-001 are also available if required (see insert). These are fixed using a screw or rivet and are suitable for use outdoors.

- HREC3** Metal End Cap

Contact

Ecoglo International Limited

Email: info@ecoglo.com Web: www.ecoglo.com



H5-001 Handrail Marker 27mm

The H5-001 Handrail Marker is designed to ensure visibility of specified building features in escape routes for compliance with NFPA 101 Life Safety Code (NFPA 101) and International Fire Code (IFC). The Handrail Marker will be effective in all light conditions including during failure of the main lighting.

COMPLIANCE

Tested to UL 1994 specifications to meet the requirements of NFPA 101 and IFC. This product has also been independently tested for use in Performance Solutions to meet the performance requirements of any performance based building codes.

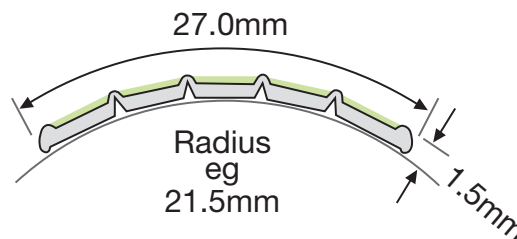
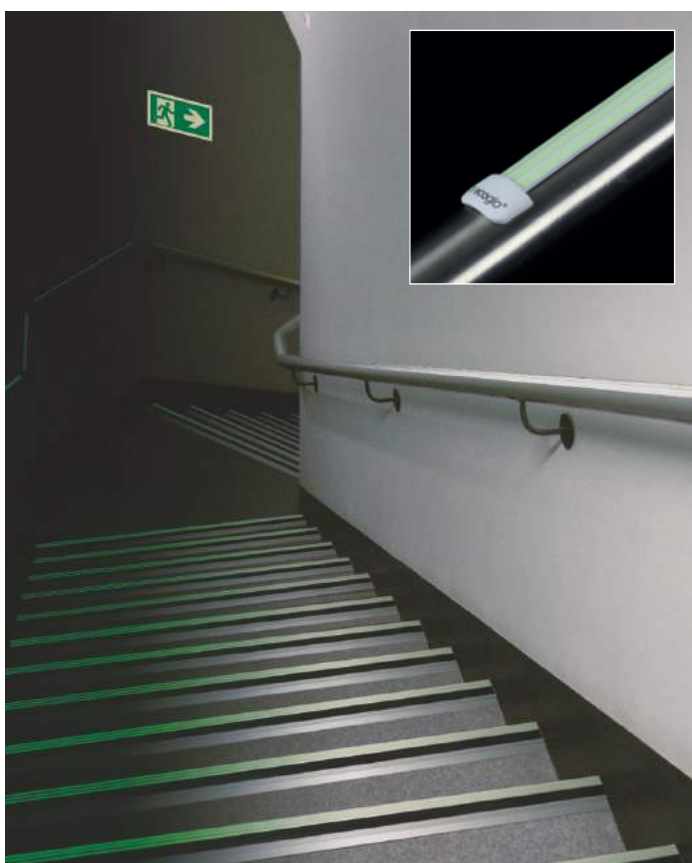

The Handrail Marker is suitable for use indoors and outdoors.

UV Resistance - Loss of luminance after 1000 hrs ASTM G-155

Cycle 1 exposure: <10%

Salt Spray Resistance – ASTM B117: Pass

Washability –ASTM D4828: Pass

Rate of Burning – ASTM D635: Pass

Surface Flammability - ASTM E162: Pass

Toxicity - Bombardier Toxic Gas Generation Test SMP800-C: Pass

Radioactivity - ASTM D3648: Pass

SUPPLY

The products are available in 1 metre and 3.06 metre lengths.

COMPOSITION

Ecoglo H5-001 Handrail Marker is manufactured from extruded 6060T5 aluminium section. Custom made photoluminescent pigments are embedded in thermoset polyester carriers to integrally bond the active ingredients into the aluminium following curing at high temperature. The photoluminescent area is also recessed into protective channels.



INSTALLATION

Installation is a simple process using pre-fitted release tape.

Consult Installation Instructions on website for full details and surface preparation.

Screws or rivets can be used if adhesion is difficult.

H5-001T-1000 Release tape pre-fitted
H5-001T-3060 Release tape pre-fitted

END CAPS

Plastic end caps to fit H5-001 are available if required (see insert).

These are fixed using polyurethane adhesive and are only suitable for use indoors.



HEC5 Plastic End Cap

Contact

Ecoglo International Limited

Email: info@ecoglo.com Web: www.ecoglo.com

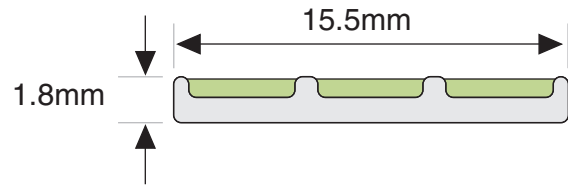

The G3-001 Guidance Strip is designed to ensure visibility of specified building features in escape routes for compliance with NFPA 101 Life Safety Code (NFPA 101) and International Fire Code (IFC), and any performance based building codes. The Guidance Strip will be effective in all light conditions including during failure of the main lighting.

COMPLIANCE

Tested to UL 1994 specifications to meet the requirements of NFPA 101 and IFC. This product has also been independently tested for use in Performance Solutions to meet the performance requirements of any performance based building codes.



The Guidance Strip is suitable for use indoors and outdoors.

UV Resistance - Loss of luminance after 1000 hrs ASTM G-155 Cycle 1 exposure: <10%

Salt Spray Resistance – ASTM B117: Pass

Washability –ASTM D4828: Pass

Rate of Burning – ASTM D635: Pass

Surface Flammability - ASTM E162: Pass

Toxicity - Bombardier Toxic Gas Generation Test SMP800-C: Pass

Radioactivity - ASTM D3648: Pass

SUPPLY

The products are available in 1 metre lengths and 3.06 metre lengths.

COMPOSITION

Ecoglo G3-001 Guidance Strip is manufactured from extruded 6060T5 aluminium section. Custom made photoluminescent pigments are embedded in thermoset polyester carriers to integrally bond the active ingredients into the aluminium following curing at high temperature. The photoluminescent area is also recessed into protective channels.



INSTALLATION

Installation is a simple process using polyurethane adhesive, fixers (screws) or pre-fitted release tape.

Fixers (screws) can be used if adhesion is difficult.

(See order codes below for the product that best suits).

Consult Installation Instructions on website for full details and surface preparation.

G3-001-1000 For polyurethane adhesive fixing
G3-001-3060 For polyurethane adhesive fixing
G3-001P-1000 Punched for screw fixing
G3-001P-3060 Punched for screw fixing
G3-001T-1000 Release tape pre-fitted
G3-001T-3060 Release tape pre-fitted

Contact

Ecoglo International Limited

Email: info@ecoglo.com Web: www.ecoglo.com

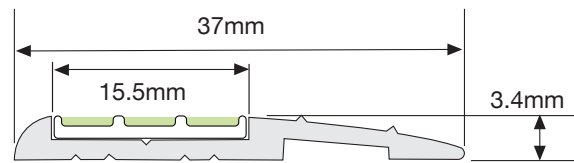
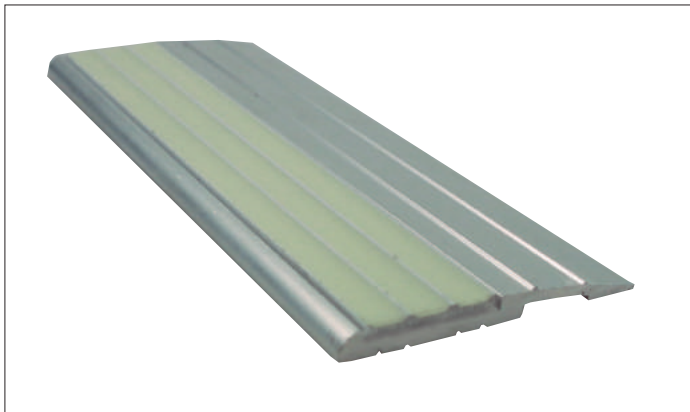

The T6-101 Path Marker is designed to ensure visibility of specified building features in escape routes for compliance with NFPA 101 Life Safety Code (NFPA 101) and International Fire Code (IFC), and any performance based building codes. The Path Marker will be effective in all light conditions including during failure of the main lighting.

COMPLIANCE

Tested to UL 1994 specifications to meet the requirements of NFPA 101 and IFC. This product has also been independently tested for use in Performance Solutions to meet the performance requirements of any performance based building codes.

The Path Marker is suitable for use indoors and outdoors.

UV Resistance - Loss of luminance after 1000 hrs ASTM G-155
Cycle 1 exposure: <10%

Salt Spray Resistance – ASTM B117: Pass

Washability – ASTM D4828: Pass

Rate of Burning – ASTM D635: Pass

Surface Flammability - ASTM E162: Pass

Toxicity - Bombardier Toxic Gas Generation Test SMP800-C: Pass

Radioactivity - ASTM D3648: Pass

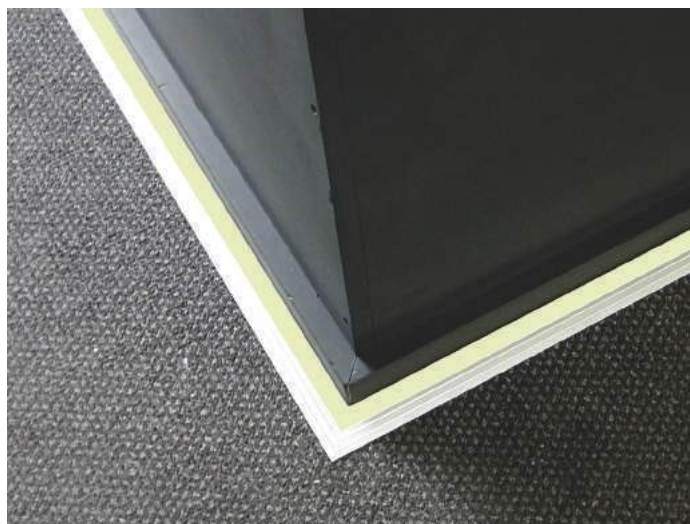

SUPPLY

The product is available in 1 metre lengths.

COMPOSITION

The Path Marker profile consists of 6060T5 aluminium extrusion, anodized (silver colour) to 12 microns thickness.

Ecoglo G3-001 is adhesively fixed into the extrusion. The high visibility G3-001 is manufactured from extruded 60605T aluminium section. Custom made photoluminescent pigments are embedded in thermoset polyester carriers to integrally bond the active ingredients into the aluminium following curing at high temperature. The photoluminescent area is also recessed into protective channels.



INSTALLATION

Designed to fit adjacent to a wall or edging, the T6-101 Path Marker can be used on a range of substrates including carpet, concrete, timber, tiles, vinyl, steel and checker plate. Uni clamp assemblies can be used for installation onto steel mesh steps. It can also be fitted over an industrial or commercial style carpet with no underlay. For thicker carpet, cut the carpet away and use a packer.

The T6-101 Path Marker can also be used to transition from one floor covering height to another.

Installation is a simple process using polyurethane adhesive or using both fixers (screws supplied) and polyurethane adhesive.

Fixers (screws) can be used if adhesion is difficult.
(See order codes below for the product that best suits).

Consult Installation Instructions on website for full details and surface preparation.

T6-101-1000 For polyurethane adhesive fixing
T6-101P-1000 Punched for screw fixing

Contact

Ecoglo International Limited

Email: info@ecoglo.com Web: www.ecoglo.com

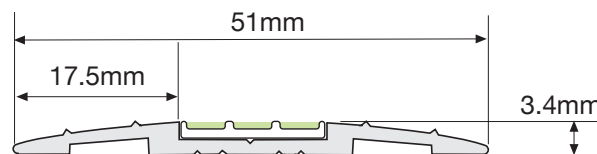

The T5-101 Path Marker is designed to ensure visibility of specified building features in escape routes for compliance with NFPA 101 Life Safety Code (NFPA 101) and International Fire Code (IFC), and any performance based building codes. The Path Marker will be effective in all light conditions including during failure of the main lighting.

COMPLIANCE

Tested to UL 1994 specifications to meet the requirements of NFPA 101 and IFC. This product has also been independently tested for use in Performance Solutions to meet the performance requirements of any performance based building codes.

The Path Marker is suitable for use indoors and outdoors.



UV Resistance - Loss of luminance after 1000 hrs ASTM G-155

Cycle 1 exposure: <10%

Salt Spray Resistance – ASTM B117: Pass

Washability –A STM D4828: Pass

Rate of Burning – ASTM D635: Pass

Surface Flammability - ASTM E162: Pass

Toxicity - Bombardier Toxic Gas Generation Test SMP800-C: Pass

Radioactivity - ASTM D3648: Pass

SUPPLY

The product is available in 1 metre lengths.

COMPOSITION

The Path Marker profile consists of 6060T5 aluminium extrusion, anodized (silver colour) to 12 microns thickness.

Ecoglo G3-001 is adhesively fixed into the extrusion. The high visibility G3-001 is manufactured from extruded 60605T aluminium section.

Custom made photoluminescent pigments are embedded in thermoset polyester carriers to integrally bond the active ingredients into the aluminium following curing at high temperature. The photoluminescent area is also recessed into protective channels.



INSTALLATION

The T5-101 Path Marker can be used on a range of substrates including carpet, concrete, timber, tiles, vinyl, steel and checker plate. Uni clamp assemblies can be used for installation onto steel mesh steps. It can also be fitted over an industrial or commercial style carpet with no underlay. For thicker carpet, cut the carpet away and use a packer.

Installation is a simple process using polyurethane adhesive or using both fixers (screws supplied) and polyurethane adhesive.

Fixers (screws) can be used if adhesion is difficult.

(See order codes below for the product that best suits).

Consult Installation Instructions on website for full details and surface preparation.

T5-101-1000 For polyurethane adhesive fixing

T5-101P-1000 Punched for screw fixing

Contact

Ecoglo International Limited

Email: info@ecoglo.com Web: www.ecoglo.com



UL-HZ2503 Hazard Tape

The UL-HZ2503 Hazard Tape is designed to ensure visibility of obstacles in escape routes for compliance with NFPA 101 Life Safety Code (NFPA 101) and International Fire Code (IFC). The Hazard Tape will be effective in all light conditions including failure of the main lighting.

COMPLIANCE

UL Listed and NFPA 101 and IFC compliant. Can be used in Performance Solutions to meet the requirements of any performance based building codes.

Brightness - High visibility in light or dark conditions meets UL 1994.

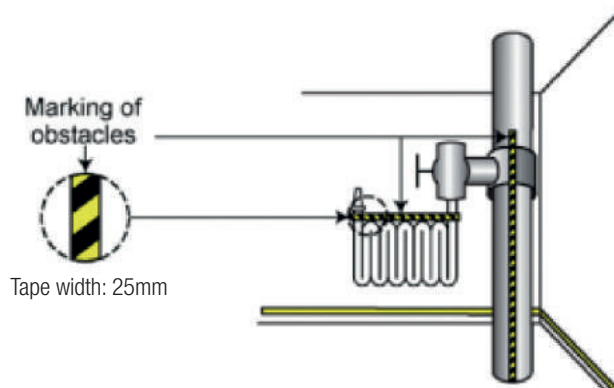

SUPPLY

The product comprises one roll of photoluminescent tape and one roll of adhesive tape and is available in rolls of 3 metres.

COMPOSITION

Manufactured using high quality vinyl, the UL-HZ2503 Hazard Tape includes a separate adhesive tape which is long lasting and provides a superior bond to a variety of surfaces.

INSTALLATION

Installation is a simple process using supplied adhesive tape.

UL-HZ2503 25mm wide x 3m roll

Contact

Ecoglo International Limited

Email: info@ecoglo.com Web: www.ecoglo.com

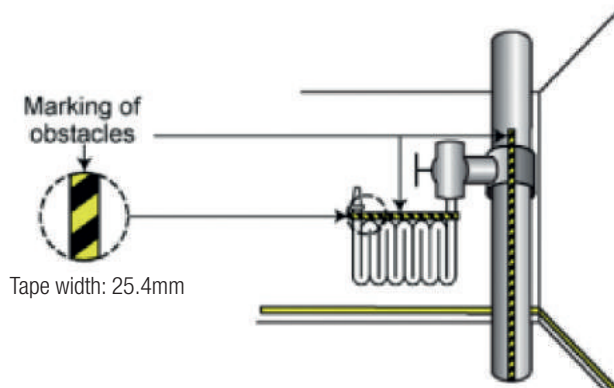

The UL-HZ2518 Hazard Tape is designed to ensure visibility of obstacles in escape routes for compliance with NFPA 101 Life Safety Code (NFPA 101) and International Fire Code (IFC). The Hazard Tape will be effective in all light conditions including failure of the main lighting.

COMPLIANCE

UL Listed and NFPA 101 and IFC compliant. Can be used in Performance Solutions to meet the requirements of any performance based building codes.

Brightness - High visibility in light or dark conditions meets UL 1994.

SUPPLY

The photoluminescent hazard tape is available in rolls of 18 metres.

COMPOSITION

Manufactured using high quality vinyl, the UL-HZ2518 Hazard Tape has a premium integrated adhesive which provides a superior bond to a variety of surfaces.

INSTALLATION

Installation is a simple process using pre-fitted release tape.

UL-HZ2518 25.4mm wide x 18m roll

Contact

Ecoglo International Limited

Email: info@ecoglo.com Web: www.ecoglo.com



Ecoglo S5 “Directional Pictogram Right Facing” signs are designed to be clearly visible to persons approaching the exit for compliance with NFPA 101 Life Safety Code and International Fire Code (IFC). The signs will be clearly visible and readily understandable under all conditions of foreseeable use, including emergency conditions.

SIGN DEFINITION

Exit straight on from here.

COMPLIANCE

Ecoglo S5 “Directional Pictogram Right Facing” signs meet ASTM E 2072 requirements and are NFPA 101 Life Safety Code and IFC compliant.

PERFORMANCE

A charging source of 1 ft-candle (11 lux) of fluorescent illumination is necessary for 60 minutes to ensure that minimum luminance requirements of 30 mcd/m² at 10 minutes and 5 mcd/m² at 90 minutes are met after failure of the main lighting.

UV Resistance – Loss of luminance after 1000 hrs ASTM G-155 Cycle 1 exposure: <10%

Salt Spray Resistance – ASTM B117: Pass

Washability – ASTM D4828: Pass

Rate of Burning – ASTM D635: Pass

Surface Flammability – ASTM E162: Pass

Toxicity – Bombardier Toxic Gas Generation Test SMP800-C: Pass

Radioactivity – ASTM D3648: Pass

SUPPLY

The product is available in the following size. (The sign can be used alone or in combination with Ecoglo directional arrow signs.)

PRODUCT CODE	PRODUCT NAME	SIGN DEFINITION	SIGN SIZE
S5-RMR1010	Directional Pictogram Right Facing	Exit straight on from here	100mm x 100mm

COMPOSITION

The high visibility flat panel is manufactured from 5005 0.9mm aluminium sheet. Custom made photoluminescent pigments are embedded in thermoset polyester carriers to integrally bond the active ingredients onto the aluminium sheet following curing at high temperature.

INSTALLATION

The sign is supplied with pre-fitted release tape for fixing flat on a wall or door.



Contact

Ecoglo International Limited

Email: info@ecoglo.com **Web:** www.ecoglo.com



Ecoglo S5 “Directional Pictogram Left Facing” signs are designed to be clearly visible to persons approaching the exit for compliance with NFPA 101 Life Safety Code and International Fire Code (IFC). The signs will be clearly visible and readily understandable under all conditions of foreseeable use, including emergency conditions.

SIGN DEFINITION

Exit straight on from here.

COMPLIANCE

Ecoglo S5 “Directional Pictogram Left Facing” signs meet ASTM E 2072 requirements and are NFPA 101 Life Safety Code and IFC compliant.

PERFORMANCE

A charging source of 1 ft-candle (11 lux) of fluorescent illumination is necessary for 60 minutes to ensure that minimum luminance requirements of 30 mcd/m² at 10 minutes and 5 mcd/m² at 90 minutes are met after failure of the main lighting.

UV Resistance – Loss of luminance after 1000 hrs ASTM G-155 Cycle 1 exposure: <10%

Salt Spray Resistance – ASTM B117: Pass

Washability – ASTM D4828: Pass

Rate of Burning – ASTM D635: Pass

Surface Flammability – ASTM E162: Pass

Toxicity – Bombardier Toxic Gas Generation Test SMP800-C: Pass

Radioactivity – ASTM D3648: Pass

SUPPLY

The product is available in the following size. (The sign can be used alone or in combination with Ecoglo directional arrow signs.)

PRODUCT CODE	PRODUCT NAME	SIGN DEFINITION	SIGN SIZE
S5-RML1010	Directional Pictogram Left Facing	Exit straight on from here	100mm x 100mm

COMPOSITION

The high visibility flat panel is manufactured from 5005 0.9mm aluminium sheet. Custom made photoluminescent pigments are embedded in thermoset polyester carriers to integrally bond the active ingredients onto the aluminium sheet following curing at high temperature.



INSTALLATION

The sign is supplied with pre-fitted release tape for fixing flat on a wall or door.

Contact

Ecoglo International Limited

Email: info@ecoglo.com **Web:** www.ecoglo.com

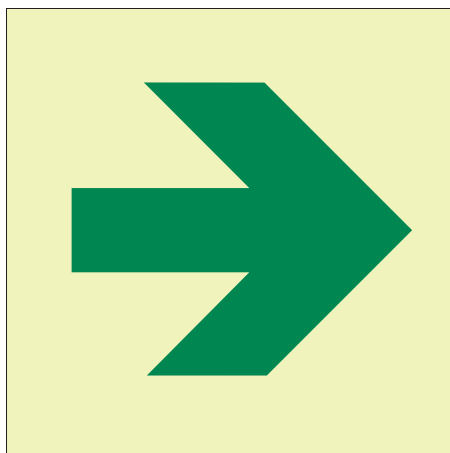

Ecoglo S5 “Directional Arrow Straight” signs are designed to be clearly visible to persons approaching the exit for compliance with NFPA 101 Life Safety Code and International Fire Code (IFC). The signs will be clearly visible and readily understandable under all conditions of foreseeable use, including emergency conditions.

SIGN DEFINITION

Travel in this direction.

COMPLIANCE

Ecoglo S5 “Directional Arrow Straight” signs meet ASTM E 2072 requirements and are NFPA 101 Life Safety Code and IFC compliant.

PERFORMANCE

A charging source of 1 ft-candle (11 lux) of fluorescent illumination is necessary for 60 minutes to ensure that minimum luminance requirements of 30 mcd/m² at 10 minutes and 5 mcd/m² at 90 minutes are met after failure of the main lighting.

UV Resistance – Loss of luminance after 1000 hrs ASTM G-155 Cycle 1 exposure: <10%

Salt Spray Resistance – ASTM B117: Pass

Washability – ASTM D4828: Pass

Rate of Burning – ASTM D635: Pass

Surface Flammability – ASTM E162: Pass

Toxicity – Bombardier Toxic Gas Generation Test SMP800-C: Pass

Radioactivity – ASTM D3648: Pass

SUPPLY

The product is available in the following size. (The sign can be used alone or in combination with Ecoglo directional pictogram signs.)

PRODUCT CODE	PRODUCT NAME	SIGN DEFINITION	SIGN SIZE
S5-ARS1010	Directional Arrow Straight	Travel in this direction	100mm x 100mm

COMPOSITION

The high visibility flat panel is manufactured from 5005 0.9mm aluminium sheet. Custom made photoluminescent pigments are embedded in thermoset polyester carriers to integrally bond the active ingredients onto the aluminium sheet following curing at high temperature.



INSTALLATION

The sign is supplied with pre-fitted release tape for fixing flat on a wall or door.

Contact

Ecoglo International Limited

Email: info@ecoglo.com **Web:** www.ecoglo.com

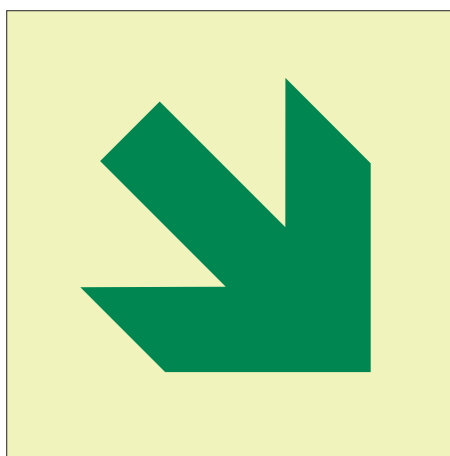

Ecoglo S5 “Directional Arrow Diagonal” signs are designed to be clearly visible to persons approaching the exit for compliance with NFPA 101 Life Safety Code and International Fire Code (IFC). The signs will be clearly visible and readily understandable under all conditions of foreseeable use, including emergency conditions.

SIGN DEFINITION

Travel in this direction.

COMPLIANCE

Ecoglo S5 “Directional Arrow Diagonal” signs meet ASTM E 2072 requirements and are NFPA 101 Life Safety Code and IFC compliant.

PERFORMANCE

A charging source of 1 ft-candle (11 lux) of fluorescent illumination is necessary for 60 minutes to ensure that minimum luminance requirements of 30 mcd/m² at 10 minutes and 5 mcd/m² at 90 minutes are met after failure of the main lighting.

UV Resistance – Loss of luminance after 1000 hrs ASTM G-155 Cycle 1 exposure: <10%

Salt Spray Resistance – ASTM B117: Pass

Washability – ASTM D4828: Pass

Rate of Burning – ASTM D635: Pass

Surface Flammability – ASTM E162: Pass

Toxicity – Bombardier Toxic Gas Generation Test SMP800-C: Pass

Radioactivity – ASTM D3648: Pass

SUPPLY

The product is available in the following size. (The sign can be used alone or in combination with Ecoglo directional pictogram signs.)

PRODUCT CODE	PRODUCT NAME	SIGN DEFINITION	SIGN SIZE
S5-ARD1010	Directional Arrow Diagonal	Travel in this direction	100mm x 100mm

COMPOSITION

The high visibility flat panel is manufactured from 5005 0.9mm aluminium sheet. Custom made photoluminescent pigments are embedded in thermoset polyester carriers to integrally bond the active ingredients onto the aluminium sheet following curing at high temperature.



INSTALLATION

The sign is supplied with pre-fitted release tape for fixing flat on a wall or door.

Contact

Ecoglo International Limited

Email: info@ecoglo.com **Web:** www.ecoglo.com

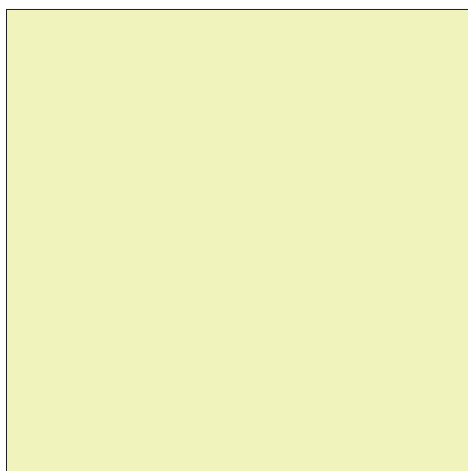

Ecoglo S5 Door Handle Markers are designed to be clearly visible to persons approaching the exit for compliance with NFPA 101 Life Safety Code and International Fire Code (IFC). The Door Handle Marker will be visible and readily understandable under all conditions of foreseeable use, including emergency conditions.

COMPLIANCE

Ecoglo S5 Door Handle Markers meet ASTM E 2072 requirements and are NFPA 101 Life Safety Code and IFC compliant.

PERFORMANCE

A charging source of 1 ft-candle (11 lux) of fluorescent illumination is necessary for 60 minutes to ensure that minimum luminance requirements of 30 mcd/m² at 10 minutes and 5 mcd/m² at 90 minutes are met after failure of the main lighting.

UV Resistance – Loss of luminance after 1000 hrs ASTM G-155

Cycle 1 exposure: <10%

Salt Spray Resistance – ASTM B117: Pass

Washability – ASTM D4828: Pass

Rate of Burning – ASTM D635: Pass

Surface Flammability – ASTM E162: Pass

Toxicity – Bombardier Toxic Gas Generation Test SMP800-C: Pass

Radioactivity – ASTM D3648: Pass

SUPPLY

The product is available in the following size.

PRODUCT CODE	PRODUCT NAME	MARKER DEFINITION	MARKER SIZE
S5-DHM1010	Door Handle Marker	Not applicable	100mm x 100mm

COMPOSITION

The high visibility flat panel is manufactured from 5005 0.9mm aluminium sheet. Custom made photoluminescent pigments are embedded in thermoset polyester carriers to integrally bond the active ingredients onto the aluminium sheet following curing at high temperature.



INSTALLATION

The door marker is supplied with pre-fitted release tape for fixing flat on a door.

Contact

Ecoglo International Limited

Email: info@ecoglo.com Web: www.ecoglo.com

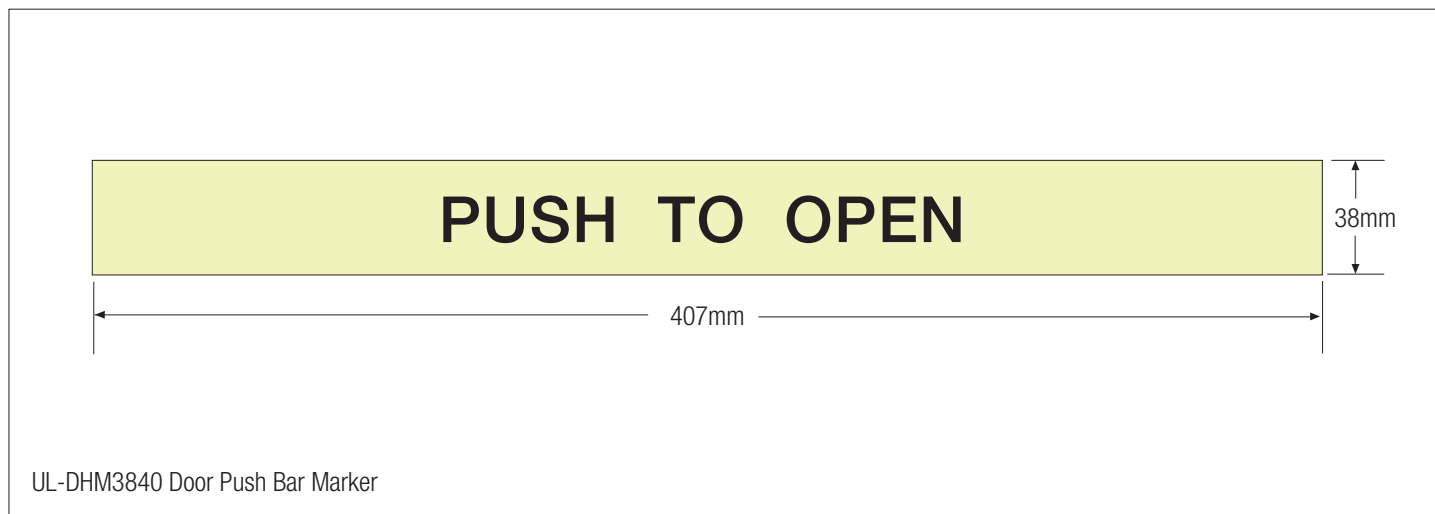

The UL-DHM3840 Door Push Bar Marker is designed to ensure visibility of panic bars on doors in escape routes for compliance with NFPA 101 Life Safety Code and International Fire Code (IFC). The Door Push Bar Marker will be effective in all light conditions including failure of the main lighting.

COMPLIANCE

UL Listed and NFPA 101 and IFC compliant. Can be used in Performance Solutions to meet the requirements of any performance based building codes.

Brightness - High visibility in light or dark conditions meets UL 1994.

SUPPLY

The product is available in the following size.

PRODUCT CODE	PRODUCT DESCRIPTION	PRODUCT LENGTH
UL-DHM3840	Door Push Bar Marker 38mm	407mm

COMPOSITION

The UL-DHM3840 Door Push Bar Marker is manufactured from high quality vinyl.

INSTALLATION

The Door Push Bar Marker is supplied with pre-fitted release tape making installation a simple process.

Contact

Ecoglo International Limited

Email: info@ecoglo.com Web: www.ecoglo.com

Appendix 2

Ecoglo International Ltd

Installation Instructions

Installation Instructions For

Major Projects with On Site Cutting

E-Series Step Edge Contrast

Ecoglo markers are to be installed only where there will be sufficient natural or artificial light to keep them charged whenever the building is occupied.

If unsure, contact Ecoglo

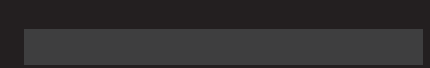

Major Projects with On Site Cutting E-Series Step Edge Contrast

Materials Required

- Work benches up to 2.0m long
- Tape measure/ruler/pencil
- Guillotine - Hand Operated Plate Shears (Model: Opti PS150 or similar)
- Hole spacing jig (using end stops and/or alignment marks)
- Bench hand punch
- Battery drill
- Drill bit for countersink
- Angle grinder (for surface preparation)
- Abrasive flap disc (for surface preparation)
- Methylated spirits and cloth
- Würth KD Bond and Seal or Bostik Seal'n'Flex FC adhesive (expected usage 25 - 30 metres per 600 ml sausage) or similar quality polyurethane adhesive
- Caulking (adhesive) gun
- Nozzles for caulking gun
- Fixers - 6G x 25mm
- Anchors (plugs) - 5 x 25mm
- Brush and pan

Major Projects with On Site Cutting E-Series Step Edge Contrast

Cutting

1. Measuring the Contrast Strip

- Measure the required length of the strip.
- Mark the position where you will cut.

2. Cutting the Contrast Strip to Length

- Contrast strips contain silicon carbide grit that rapidly blunt high-speed saw blades, so a manual guillotine - also referred to as hand shears (example pictured below) - is needed to cut the strip.
- Lay the strip, upside down, into the guillotine.
- Use the guillotine to cut the strip - it is recommended that the strips are always cut while upside down to eliminate potential bruising of the strip.
- Cut the strip at the length measured.

NOTE: The maximum recommended length for installation in outdoor situations is 1.5 metres, with a minimum 3mm gap between lengths. This allows for thermal expansion in extreme weather conditions and also aids in water drainage off the step tread.



Guillotine - Model: Opti PS150

Punch Fixer Holes (if using fixers)

- Refer to the hole drilling/punching specification table below to determine positioning and number of holes.
- Ensure outside holes are approximately 50 mm in from each end.
- Mark where holes are to be made - this should be through the anti-slip material.
- Using a bench hand punch (example below) create holes for fixers.
- If countersinking is required, use a hand drill and countersink drill bit to make fixer flush with strip.

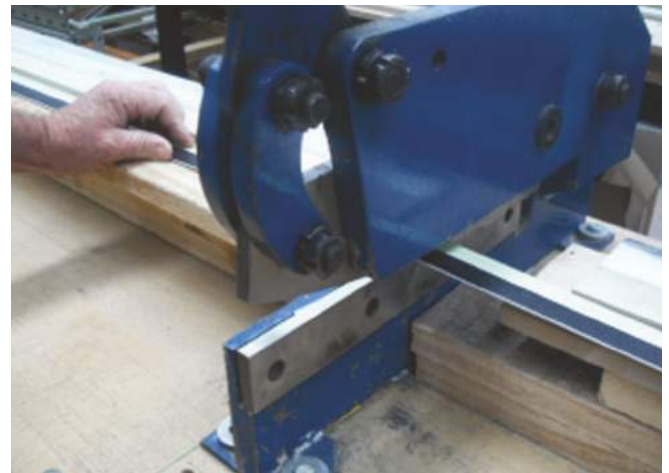

Using guillotine (hand shears) to cut strip



Bench Hand Punch - Model Bramley 023 (HP-10), 3-10mm

Hole Drilling Specifications

Strip Length	Less than 350mm	350mm - 650mm	650mm - 950mm	950mm - 1250mm	1250mm - 1500mm
Number of Holes	2	3	4	5	6

Major Projects with On Site Cutting E-Series Step Edge Contrast

Installation

1. Preparation of Surface

- Thoroughly clean the surface with industrial strength cleaner if necessary.
- Allow surface to dry.
- If painted, sealed or coated, remove using an angle grinder with abrasive flap disc (see image below).
- Brush/vacuum off the dust.
- Wipe surface with acetone.



Note: Installation onto Concrete Surfaces

- It is preferable to use adhesive only for concrete installations. The adhesive will allow some movement to compensate for thermal contraction and expansion and will provide durable adhesion to the concrete substrate.

** Where adhesive only installation is preferred on surfaces that have a sealer applied (eg concrete, exposed aggregate and some tiles) a test patch should be laid and allowed to temperature cycle over a minimum of 14 days to ensure a good bond is achieved.*

If the adhesive does not hold then mechanical fixers should be used.

If mechanical fixing is not practical due to potential damage to the substrate please contact Ecoglo.

2. Alignment of the Strips

- Mark 50mm from the left edge of the top step.
- Mark 50mm from the left edge of the bottom step.
- Place a string line between the marks to ensure the strip on each step will be correctly aligned.

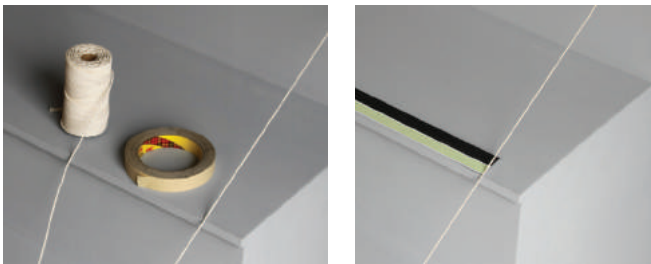

- The maximum recommended length for installation in outdoor situations is 1.5 metres.
- There must be a 3mm gap between lengths. This allows for thermal expansion in extreme weather conditions and also aids in water drainage off the step tread.
- Leave a 3mm gap either side of built-in steps

3. Preparation of the Strip

- Clean back of contrast strip with soft cloth and if necessary use methylated spirits (or similar solvent) to remove oil or grease
- Allow to dry for approximately 1 minute.

4. Applying the Adhesive

- Apply a 3mm zigzag bead of polyurethane adhesive (such as Wurth KD Bond and Seal or Bostik Seal n Flex FC) to the back of the strip, 3mm in from the edges.
- Take care to keep adhesive away from any drill holes.
- Continue along the length of the strip.



Adhesive Usage:

E2 Series - 30 metres per 600ml

E4 Series - 25 metres per 600ml

E14 Series - 25 metres per 600ml

Ecoglo can supply Wurth KD Bond and Seal in 600ml Sausage form with Applicator Gun.

5. Placement of the Strip

- Line up the strip with your alignment marks and position approximately 2-3mm back from the front straight edge of the step.
- Place in position with the photoluminescent (light green) component of the strip to the leading edge of the step (see image below).

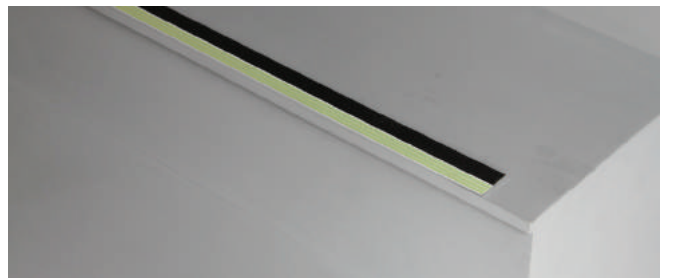

Steps with exposed sides:

Ensure the nosing is set back from exposed side by at least 20mm to ensure the outer edge of the nosing does not present a sharp hazard.

Tile Steps:

If the tiles are not perfectly aligned then the contrast strip must be cut into pieces the width of each tile and placed so that the grout line is exposed.

Major Projects with On Site Cutting E-Series Step Edge Contrast

6. Apply Pressure to the Strip

- Apply even pressure to spread the adhesive beneath the strip using a hand roller.
- If necessary stand on each strip to ensure good contact between the strip and the step.



7. Allow the Adhesive to Cure

- Immediately following installation close off the area for a period of 8 hours to avoid the Ecoglo strip being moved whilst the adhesive is in the early stages of "cure".
- Wait until adhesive has fully cured (allow at least 24 hours) before trimming any excess from each strip with a sharp blade.
- Leave the adhesive to cure for 7 days before installing the fixers.

8. Installing the Fixers (if required)

- Place a screw fixer into each hole and drill in securely using a battery drill.
- Do not fully tighten the fixers to avoid compressing the adhesive.



Installation Instructions For

Major Projects with On Site Cutting

F-Series Step Nosings

Ecoglo markers are to be installed only where there will be sufficient natural or artificial light to keep them charged whenever the building is occupied.

If unsure, contact Ecoglo



Major Projects with On Site Cutting F-Series Step Nosings

Materials Required

- Work benches up to 2.0m long
- Input/output benching or racks
- Tape measure/ruler/pencil
- Drop saw with high speed tungsten carbide tip blade (eg Sash Pro 250mm diameter, 80 tooth) mounted on bench with support arms/guides for extrusions, and adjustable end stops
- Guillotine - Hand Operated Plate Shears (Model: Opti PS150, seen over page, or similar)
- Brush and pan
- Methylated spirits and cloth
- String
- Battery drill
- Drill suitable for concrete substrate
- 6mm masonry drill bits
- Anchors (plugs) - 6mm x 30mm
- Würth KD Bond and Seal or Bostik Seal'n'Flex FC adhesive (expected usage 11 metres per 600 ml sausage) or similar quality polyurethane adhesive
- Caulking (adhesive) gun
- Nozzles for caulking gun
- Fixers - 8G x 32mm
- Hand press-roller
- Alcohol wipes

Major Projects with On Site Cutting F-Series Step Nosings

Cutting

1. Measuring the Nosing and Insert

- Measure the required length of the nosing and the insert.
- Mark the position on both pieces where you will cut.



2. Cutting the Nosing to Length

- Use the drop saw with a suitable tungsten carbide tip blade.
- Cut the nosing at the length measured.

NOTE: The maximum recommended length for installation in outdoor situations is 1.5 metres, with a minimum 3mm gap between lengths. This allows for thermal expansion in extreme weather conditions and also aids in water drainage off the step tread.



3. Cutting the Insert to Length

- Step edge contrast inserts contain silicon carbide grit that rapidly blunt high-speed saw blades, so a manual guillotine (as pictured below) is needed to cut the insert.
- Lay the insert strip, upside down, into the pre-cut nosing. Mark the insert strip for cutting.
- Remove the insert strip from the nosing and place into the guillotine. Use the guillotine to cut the insert - it is recommended that the inserts are always cut while upside down to eliminate potential bruising of the contrast strip.

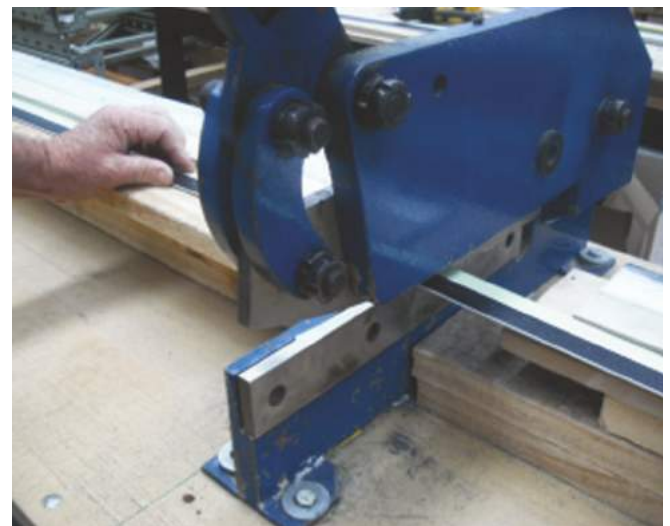

Major Projects with On Site Cutting F-Series Step Nosings

Installation

1. Preparation of Surface

- Brush the surface clean of dust and debris. If necessary, clean with an industrial cleaner.
- Remove any paint or sealant and then allow the surface to dry.
- It is better for adhesion if timber surfaces are dry.



Steps with exposed sides:

Ensure the nosing is set back from exposed side by at least 20mm to ensure the outer edge of the nosing does not present a sharp hazard.

Built-in steps, Installed outdoors:

Leave a 3mm gap between the nosing and the built-in sides, to allow for thermal expansion, and water drainage.

NOTE: The maximum recommended length for installation in outdoor situations is 1.5 metres. A 3mm expansion / drainage gap must be left between lengths.

2. Alignment (for installation onto more than one step)

- Place one piece of step nosing on the top step and one on the bottom step.
- Run a string line from the left edge of the top nosing to the left edge of the bottom nosing.
- This will give you a straight, true line.



3. Locating Holes for Fixers (for Timber skip to step 5)

- Place the nosing firmly against the riser of the step.
- Line it up with your string line.
- Mark the location of the drill holes with the drill.
- Remove the nosing.

NOTE: The F14 and F15 nosings come pre-drilled with holes every 100mm. You only require 4 fixers per metre. Fixers should be zig-zagged across the pre-drilled holes to give maximum support to both sides of the nosing.

4. Drilling holes for fixers (for Timber skip to step 5)

- Using a 6mm masonry bit, and a concrete drill, drill the hole that will house the plastic anchor.
- Wipe away any dust or debris.
- Place the plastic anchor fully in to the holes.



5. Applying Adhesive

- Lay a 3mm bead of polyurethane adhesive (such as Wurth KD Bond and Seal or Bostik Seal n Flex FC) in a wave pattern over the full length of the underside of the nosing.
- Keep the adhesive clear of the outside edge and the drill holes.



Major Projects with On Site Cutting F-Series Step Nosings

6. Securing the nosing profile

- Place the nosing firmly back onto the step, lining up the drill holes.
- Tighten the screws firmly using a battery hand drill- this will create a strong, even bond.
- For fixing on to wooden substrate follow the previous instructions but the plugs are not required.

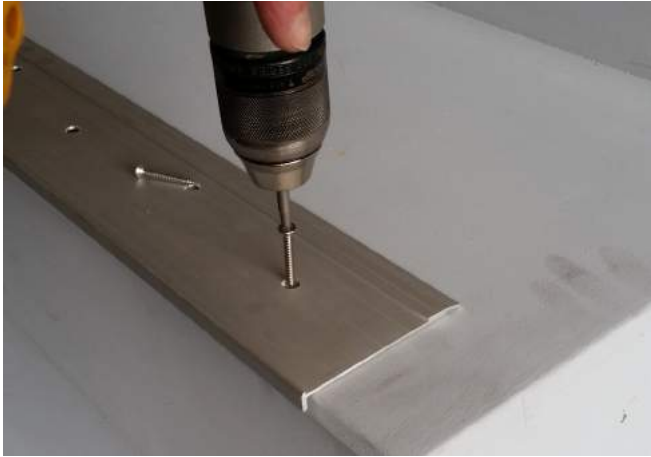

Adhesive Usage:

11 metres per 600ml sausage

Ecoglo supply screw fixers with all orders and can also supply Wurth KD Bond and Seal in 600ml Sausage form with Applicator Gun.

7. Fixing Insert Strip

- Check nosing extrusion channel is free from dust, dirt, grease and moisture.
- Dust or wipe with methylated spirits or damp cloth if required.
- Lay a zigzag of adhesive, 1mm deep, 3mm wide on to the strip.
- Ensure that you don't over apply adhesive as it will spill out once the insert is placed into the nosing.



8. Insert strip into the nosing

- Line up the strip insert then place firmly onto the nosing.
- Press in place to ensure even contact between the adhesive and the surface of the channel.
- Use a roller or your foot to apply firm downward pressure.
- Use an alcohol wipe to remove any spill over of adhesive.

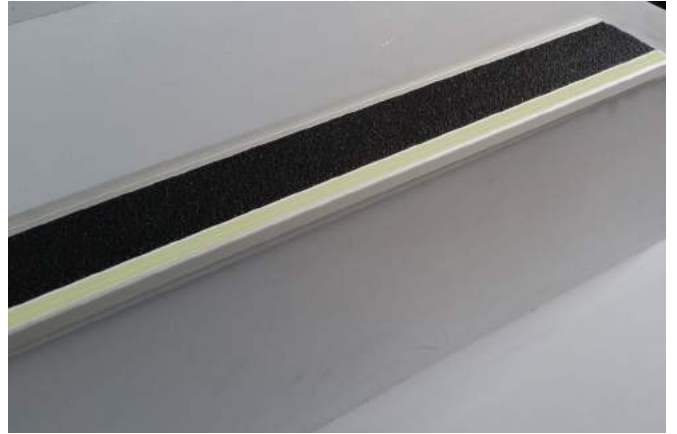

9. Curing of Adhesive

- Allow approximately 24 hours for adhesive to cure.

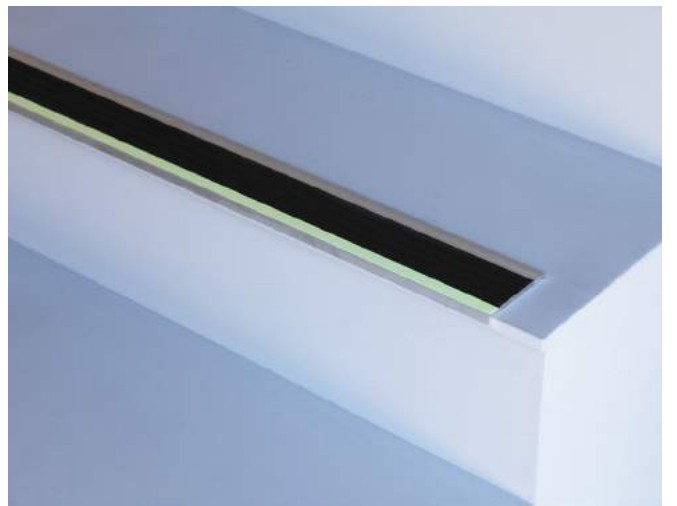

Installation Instructions For

Step Edge Contrast E Series

Concrete and Timber

Ecoglo markers are to be installed only where there will be sufficient natural or artificial light to keep them charged whenever the building is occupied.

If unsure, contact Ecoglo



Step Edge Contrast - E Series Concrete and Timber

1. Preparation of Surface

- Thoroughly clean the surface with industrial strength cleaner if necessary.
- Remove any loose paint or sealant and then allow surface to dry.
- If painted or coated, check that adhesive is compatible with the paint or seal coating*. IF IN DOUBT REMOVE COATING.



Note: Installation onto Concrete Surfaces

- It is important to use adhesive only for concrete installations. The adhesive will allow some movement to compensate for thermal contraction and expansion and will provide durable adhesion to the concrete substrate.

* Where adhesive only installation is preferred on surfaces that have a sealer applied (eg exposed aggregate and some tiles) a test patch should be laid and allowed to temperature cycle over a minimum of 14 days to ensure a good bond is achieved.

If the adhesive does not hold then mechanical fixers should be used.

If mechanical fixing is not practical due to potential damage to the substrate please contact Ecoglo.

2. Alignment of the Strips

- Mark 50mm from the left edge of the top step.
- Mark 50mm from the left edge of the bottom step.
- Place a string line between the marks to ensure the strip on each step will be correctly aligned.



- The maximum recommended length for installation in outdoor situations is 1.5 metres.
- There must be a 3mm gap between lengths. This allows for thermal expansion in extreme weather conditions and also aids in water drainage off the step tread.
- Leave a 3mm gap either side of built-in steps

3. Preparation of the Strip

- Clean back of contrast strip with soft cloth and if necessary use methylated spirits (or similar solvent) to remove oil or grease
- Allow to dry for approximately 1 minute.

4. Applying the Adhesive

- Apply a 3mm zigzag bead of polyurethane adhesive (such as Wurth KD Bond and Seal or Bostik Seal n Flex FC) to the back of the strip, 3mm in from the edges.
- Continue along the length of the strip.



Adhesive Usage:

E2 Series - 30 metres per 600ml

E4 Series - 25 metres per 600ml

E14 Series - 25 metres per 600ml

Ecoglo can supply Wurth KD Bond and Seal in 600ml Sausage form with Applicator Gun.

5. Placement of the Strip

- Line up the strip with your alignment marks and position approximately 2-3mm back from the front straight edge of the step.
- Place in position with the photoluminescent (light green) component of the strip to the leading edge of the step (see image below).

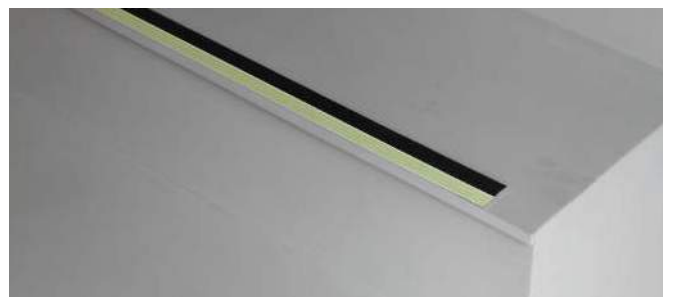

Steps with exposed sides:

Ensure the nosing is set back from exposed side by at least 20mm to ensure the outer edge of the nosing does not present a sharp hazard.

Tile Steps

If the tiles are not perfectly aligned then the contrast strip must be cut into pieces the width of each tile and placed so that the grout line is exposed.

Step Edge Contrast - E Series Concrete and Timber

6. Apply Pressure to the Strip

- Apply even pressure to spread the adhesive beneath the strip using a hand roller.
- If necessary stand on each strip to ensure good contact between the strip and the step.



7. Allow the Adhesive to Cure

- Immediately following installation close off the area for a period of 8 hours to avoid the Ecoglo strip being moved whilst the adhesive is in the early stages of “cure”.
- Wait until adhesive has fully cured (allow at least 24 hours) before trimming any excess from each strip with a sharp blade.

8. Use of Fixers (for Outdoor Timber installations only)

Note: Indoor installations only require adhesive

Outdoor Timber becomes a two step process

For outdoor timber installations both adhesive and fixers should be used because installation onto outdoor timber surfaces varies due to the uneven nature of timber, the various types of timber (eg pine or kwila), the protective coating (eg paint or sealer) and seasonal temperature variances.

Step 1:

- Apply adhesive as per steps 3-4 taking care to keep adhesive away from pre drilled holes.
- Place strip as per steps 5-6.
- Leave the adhesive to cure for 7 days before installing the fixers.

Step 2:

- Place a screw fixer into each hole and drill in securely using a battery drill.
- Do not fully tighten the fixers to avoid compressing the adhesive.

For timber installations the strips should be pre-drilled through the anti-slip material. The table below shows the number of drill holes required to allow for the natural contraction and expansion of timber.



Hole Drilling Specifications

Hole Drilling Specification	Less than 350mm	350mm - 650mm	650mm - 950mm	950mm - 1250mm	1250mm - 1500mm
Number of Holes	2	3	4	5	6

Holes for fixers are usually drilled as part of manufacturing. If for any reason the product was ordered, or supplied, without holes where fixers are required then Ecoglo recommend the hole spacings shown in the table above for maximum durability.

Step Edge Contrast - E Series Release tape pre-fitted (indoor use only)

Note: Strips with pre-fitted release tape are suitable only for indoor use on steps which are not subject to daily use or heavy foot traffic. Surfaces must be level and thoroughly prepared.

If any doubts about use, please contact Ecoglo for advice at info@ecoglo.com.

1. Preparation of Surface

- Thoroughly clean the surface with industrial strength cleaner if necessary.
- Remove any loose paint or sealant and then allow surface to dry.
- If painted or coated, check that adhesive is compatible with the paint or seal coating. IF IN DOUBT REMOVE COATING

2. Alignment of the Strips

- Mark 50mm from the left edge of the top step.
- Mark 50mm from the left edge of the bottom step.
- Place a string line between the marks to ensure the strip on each step will be correctly aligned.
- Offer up the strip to the step it is to be attached to make sure both surfaces are parallel.

Note:

The maximum recommended length for installation is 1.5 metres.

Leave a 3mm gap either side of built-in steps.

3. Placement of Adhesive-backed Strip

- Carefully peel off the release-tape backing from the strip.
- Carefully line the strip up with any alignment marks.
- Press the strip firmly in place to ensure even contact between the adhesive tape and the surface to which it is being applied.



Installation Instructions For

Step Nosing F Series

Two-Part Installation Concrete and Timber

Ecoglo markers are to be installed only where there will be sufficient natural or artificial light to keep them charged whenever the building is occupied.

If unsure, contact Ecoglo



1. Preparation of Surface

- Brush the surface clean of dust and debris. If necessary, clean with an industrial cleaner.
- Remove any paint or sealant and then allow the surface to dry.
- It is better for adhesion if timber surfaces are dry.



Steps with exposed sides:

Ensure the nosing is set back from exposed side by at least 20mm to ensure the outer edge of the nosing does not present a sharp hazard.

Built-in steps, Installed outdoors:

Leave a 3mm gap between the nosing and the built-in sides, to allow for thermal expansion, and water drainage.

NOTE: The maximum recommended length for installation in outdoor situations is 1.5 metres. A 3mm expansion / drainage gap must be left between lengths.

2. Alignment (for installation onto more than one step)

- Place one piece of step nosing on the top step and one on the bottom step.
- Run a string line from the left edge of the top nosing to the left edge of the bottom nosing.
- This will give you a straight, true line.



3. Locating Holes for Fixers (for Timber skip to step 5)

- Place the nosing firmly against the riser of the step.
- Line it up with your string line.
- Mark the location of the drill holes with the drill.
- Remove the nosing.

NOTE: The F14-175 nosing comes pre-drilled with holes every 100mm. You only require 4 fixers per metre. Fixers should be zig-zagged across the pre-drilled holes to give maximum support to both sides of the nosing.

4. Drilling holes for fixers (for Timber skip to step 5)

- Using a 6mm masonry bit, and a concrete drill, drill the hole that will house the plastic anchor.
- Wipe away any dust or debris.
- Place the plastic anchor fully in to the holes.



5. Applying Adhesive

- Lay a 3mm bead of polyurethane adhesive (such as Wurth KD Bond and Seal or Bostik Seal n Flex FC) in a wave pattern over the full length of the underside of the nosing.
- Keep the adhesive clear of the outside edge and the drill holes.



6. Securing the nosing profile

- Place the nosing firmly back onto the step, lining up the drill holes.
- Tighten the screws firmly using a battery hand drill- this will create a strong, even bond.
- For fixing on to wooden substrate follow the previous instructions but the plugs are not required.



Adhesive Usage:

11 metres per 600ml sausage

Ecoglo supply screw fixers with all orders and can also supply Wurth KD Bond and Seal in 600ml Sausage form with Applicator Gun.

7. Fixing Insert Strip

- Check nosing extrusion channel is free from dust, dirt, grease and moisture.
- Dust or wipe with methylated spirits or damp cloth if required.
- Lay a zigzag of adhesive, 1mm deep, 3mm wide on to the strip.
- Ensure that you don't over apply adhesive as it will spill out once the insert is placed into the nosing.



8. Insert strip into the nosing

- Line up the strip insert then place firmly onto the nosing.
- Press in place to ensure even contact, between the adhesive, and the surface of the channel.
- Use a roller or your foot to apply firm downward pressure.
- Use an alcohol wipe to remove any spill over of adhesive.

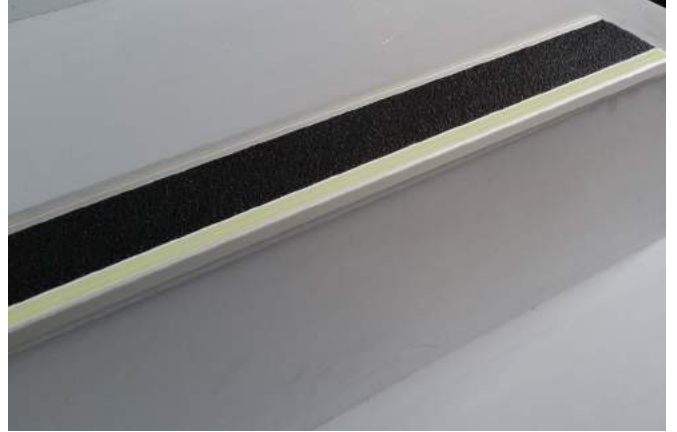

9. Curing of Adhesive

- Allow approximately 24 hours for adhesive to cure.

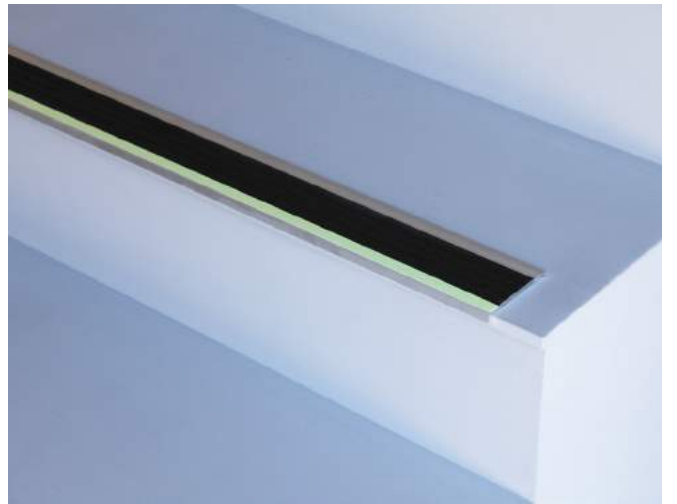

Installation Instructions For

Step Nosing F Series

Concrete and Timber

Ecoglo markers are to be installed only where there will be sufficient natural or artificial light to keep them charged whenever the building is occupied.

If unsure, contact Ecoglo



1. Preparation of Surface

- Brush the surface clean of dust and debris. If necessary, clean with an industrial cleaner.
- Remove any paint or sealant and then allow the surface to dry.
- It is better for adhesion if timber surfaces are dry.



Steps with exposed sides:

Ensure the nosing is set back from exposed side by at least 20mm to ensure the outer edge of the nosing does not present a sharp hazard.

2. Alignment (for installation onto more than one step)

- Place one piece of step nosing on the top step and one on the bottom step.
- Run a string line from the left edge of the top nosing to the left edge of the bottom nosing.
- This will give you a straight, true line.

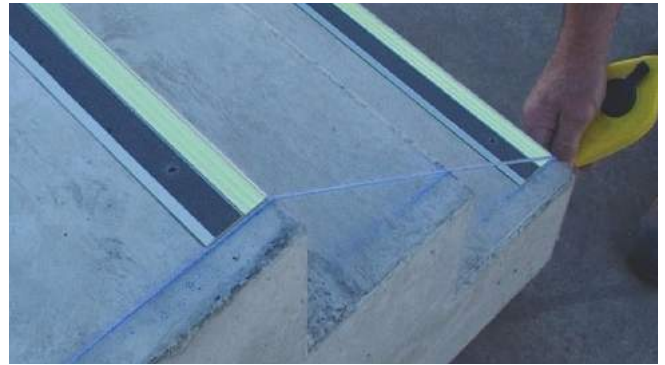

Built-in steps, Installed outdoors:

Leave a 3mm gap between the nosing and the built-in sides, to allow for thermal expansion, and water drainage.

NOTE: The maximum recommended length for installation in outdoor situations is 1.5 metres. A 3mm expansion / drainage gap must be left between lengths.

3. Locating Holes for Fixers (for Timber skip to step 5)

- Place the nosing firmly against the riser of the step.
- Line it up with your string line.
- Mark the location of the drill holes with the drill.
- Remove the nosing.



4. Drilling holes for fixers (for Timber skip to step 5)

- Using a 6mm masonry bit, and a concrete drill, drill the hole that will house the plastic anchor.
- Wipe away any dust or debris.
- Place the plastic anchor fully in to the holes.



5. Applying Adhesive

- Lay a 3mm bead of polyurethane adhesive (such as Wurth KD Bond and Seal or Bostik Seal n Flex FC) in a wave pattern over the full length of the underside of the nosing.
- Keep the adhesive clear of the outside edge and the drill holes.



Adhesive Usage:
22 metres per 600ml sausage

Ecoglo supply screw fixers with all orders and can also supply Wurth KD Bond and Seal in 600ml Sausage form with Applicator Gun.

6. Fixing the Nosing

- Place the nosing firmly back onto the step, lining up the drill holes.
- Tighten the screws firmly using a battery hand drill- this will create a strong, even bond.
- For fixing on to wooden substrate follow the previous instructions but the plugs are not required.



7. Curing of Adhesive

- Use an alcohol wipe to remove any spill over of adhesive. Allow approximately 24 hours for adhesive to cure.



 **ecoglo**[®]
VISIBLY BETTER

Ecoglo International Limited
Email: info@ecoglo.com
www.ecoglo.com



Installation Instructions For

Guidance Strips G Series (Adhesive)

Flat Surfaces

Ecoglo markers are to be installed only where there will be sufficient natural or artificial light to keep them charged whenever the building is occupied.

If unsure, contact Ecoglo



Ecoglo G-Series guidance strips are extremely versatile and can be applied on various types of surface, including walls, skirting board, floors, door frames and flat sided handrails. Generally, as long as the substrate is clean, flat and dry the product can be successfully installed.

(If in doubt about adhesion, see Section 8 of these instructions.)

1. Preparation of Surface

- Thoroughly clean the surface with an industrial strength cleaner if necessary.
- Remove any loose paint or sealant and then allow the surface to dry.
- If the surface has been painted or coated, check that adhesive is compatible with the paint or seal coating.
IF IN DOUBT REMOVE COATING.
- Maximum installation length is 1500mm.

2. Positioning, Alignment of the Strips

- If installing on a flat handrail or other surface such as a wall, mark the position where the strip is to be placed. Use a chalkline, plumb-line or spirit level if necessary to ensure the line is straight.
- Offer up the strip to the surface it is to be attached to, to make sure both surfaces are parallel. If the strip does not sit perfectly flat against the surface without being held in place, carefully bend the strip until it sits perfectly flat against the surface.

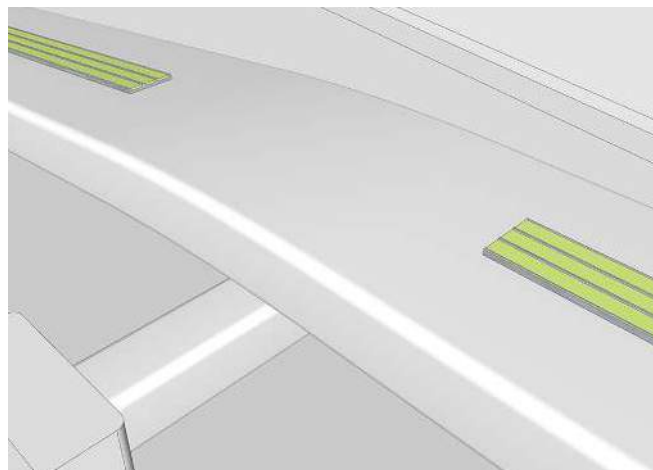
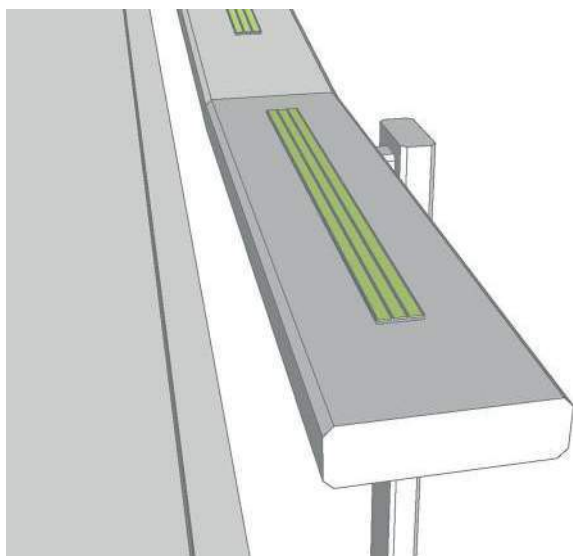

Do not bend guidance strips over bends. Set the strip 50mm from the bend.

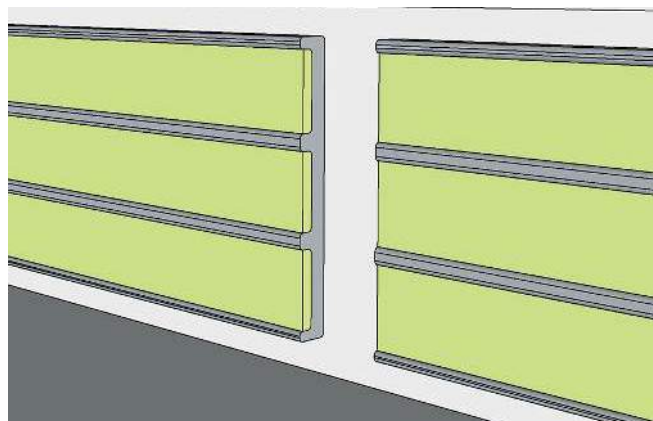

Where strips are to be butted together, there must always be a 3mm expansion gap between them. This allows for expansion and contraction between the Ecoglo strip and the building surface.

3. Preparation of the Strip

- Clean back of the strip with a soft cloth and if necessary use methylated spirits or similar solvent to remove oil or grease.
- Allow to dry for approximately 1 minute.

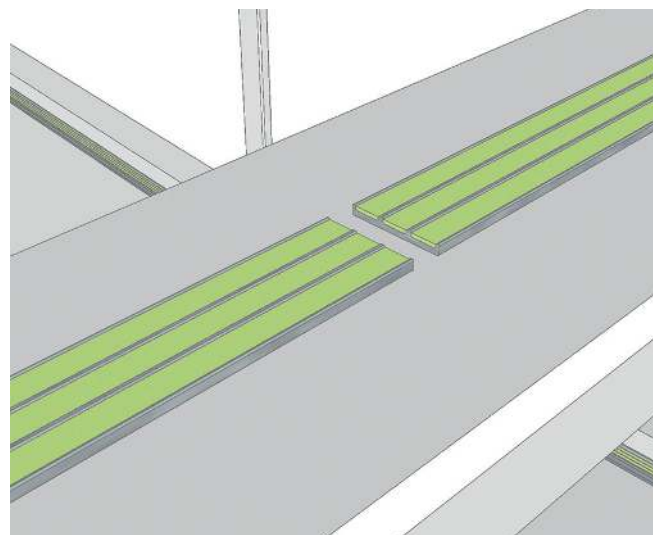

Guidance strip can be used to mark corridors, lobbies and indoor lengths of path and can be mounted either on the floor within 100mm of the wall, or on the wall within 100mm of the floor. Gaps of 3mm must be placed between strips.

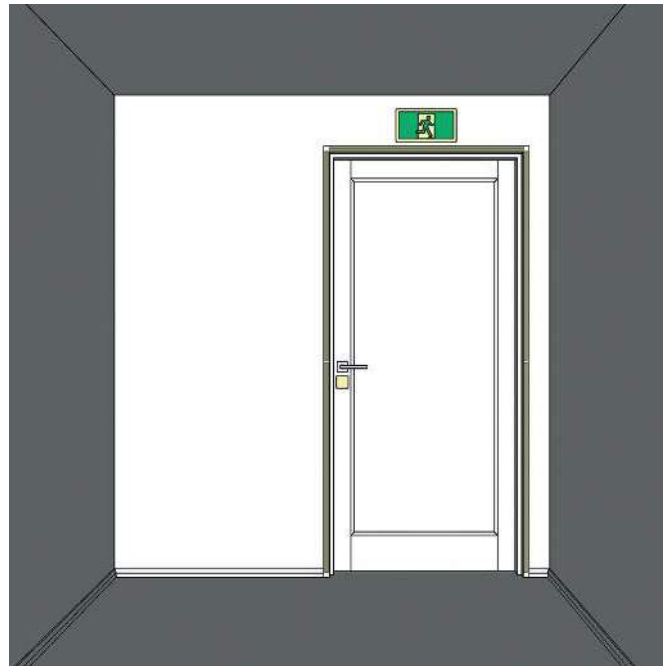
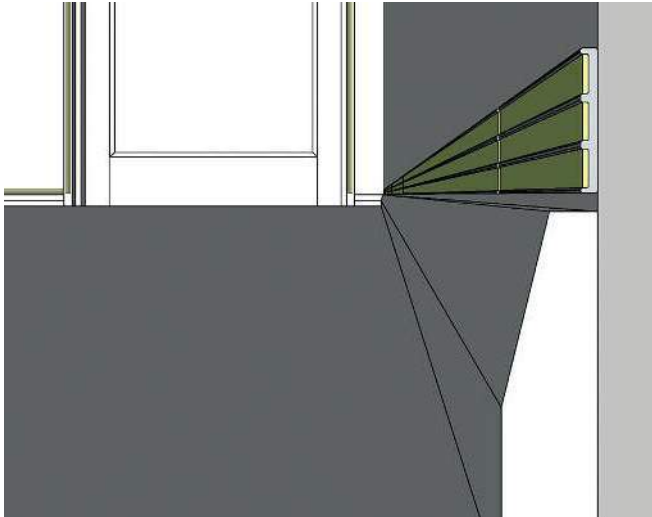

4. Applying the Adhesive

- Apply a 3mm bead of polyurethane adhesive (such as Wurth KD Bond and Seal or Bostik Seal'n'Flex FC) in a wave pattern along the full length of the back of the strip, keeping 3mm in from the edges.

Adhesive Usage: 80 metres per 600ml.

Ecoglo can supply Wurth KD Bond and Seal in 600ml Sausage form with Applicator Gun.

5. Placement of the Strip

- Line up the strip with your alignment marks. Press the strip firmly in place to ensure even contact between the strip and the surface to which it is being applied.

6. Apply Pressure to the Strip

- Apply even pressure to spread the adhesive beneath the strip using a hand roller.

7. Curing of Adhesive

- Use an alcohol wipe to remove any spillover adhesive. Allow approximately 24 hours for adhesive to cure.

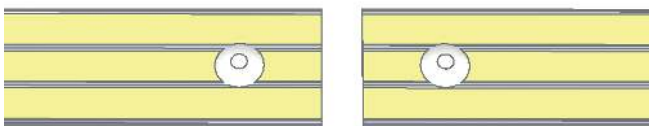

For guidance strips on handrails used in schools or public places, screws or rivets must be installed 10 – 15mm in from the end of each strip.

8. Mechanical Fixers (Screws or Rivets)

- For handrails in schools or other places where vandalism may occur, screws (for timber) or rivets (for metal) **MUST** be used. Install one screw/rivet 10-15mm in from each end of each strip.
- For outdoor timber installations screws **MUST** also be used so that the strip isn't able to lift if the timber distorts or absorbs moisture due to normal weather conditions. 5mm pan head screws are suitable to be screwed down firmly. Install one screw 10-15mm in from each end and one screw in the middle of each strip.
- If in doubt about the adhesion of the strips to any substrate, use screws/rivets for additional security. Install one 10-15mm in from each end and one in the middle of each strip.

Installation Instructions For

Guidance Strips G Series (Tape)

Flat Surfaces

Ecoglo markers are to be installed only where there will be sufficient natural or artificial light to keep them charged whenever the building is occupied.

If unsure, contact Ecoglo

Ecoglo G-Series guidance strips are extremely versatile and can be applied on various types of surface, including walls, skirting board, floors, door frames, flat sided handrails and steps*. Generally, as long as the substrate is clean, flat and dry the product can be successfully installed.

Ecoglo G-Series guidance strips have a self-adhesive backing with a release tape for simple installation. (See Section 4 of these instructions if in any doubt about adhesion).

***Ecoglo G6-003 guidance strips are suitable for use on indoor steps which are not subject to daily use or heavy foot traffic. For outdoor steps, or steps which will be subjected to frequent or heavy foot traffic, visit www.ecoglo.com or contact Ecoglo at info@ecoglo.com for information on more suitable Ecoglo products.**

1. Preparation of Surface

- Thoroughly clean the surface with an industrial strength cleaner if necessary.
- Remove any loose paint or sealant and then allow the surface to dry.
- If the surface has been painted or coated, check that adhesive is compatible with the paint or seal coating.
IF IN DOUBT REMOVE COATING.
- The tape is suitable for a temperature range of 0-40C.
- Maximum installation length is 1500mm.

2. Positioning, Alignment of the Strips

- If installing on a flat handrail or other surface such as a wall, mark the position where the strip is to be placed. Use a chalkline, plumb-line or spirit level if necessary to ensure the line is straight.
- If installing on steps, mark 50mm from the left edge of the top step, and 50mm from the left edge of the bottom step. Place a string line between the marks to ensure the strip on each step will be correctly aligned. This will give a straight, true line.
- Offer up the strip to the surface it is to be attached to, to make sure both surfaces are parallel. If the strip does not sit perfectly flat against the surface without being held in place, carefully bend the strip until it sits perfectly flat against the surface.

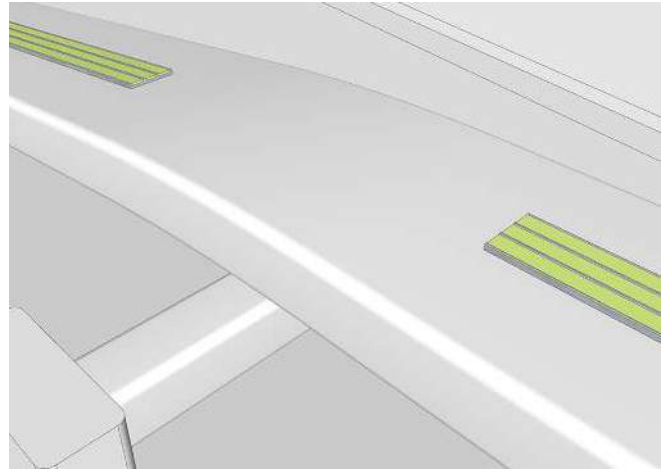
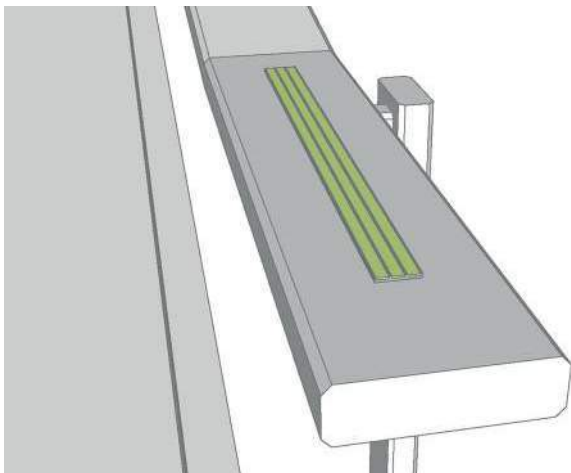

Do not bend guidance strips over bends. Set the strip 50mm from the bend.

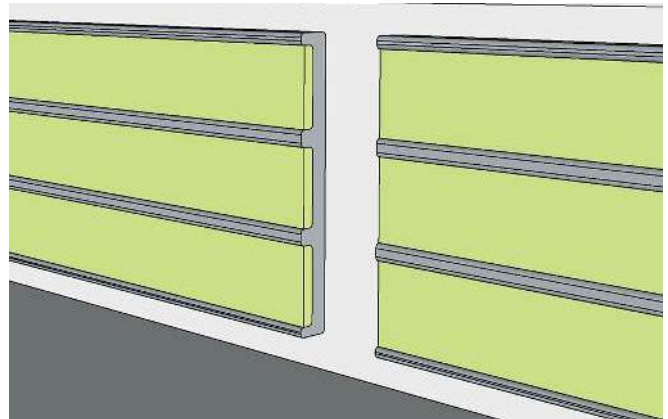

Where strips are to be butted together, there must always be a 3mm expansion gap between them. This allows for expansion and contraction between the Ecoglo strip and the building surface.

3. Placement of Adhesive-backed Strip

- Carefully peel off the release-tape backing from the strip.
- Carefully line the strip up with any alignment marks.
- Press the strip firmly in place to ensure even contact between the adhesive tape and the surface to which it is being applied.

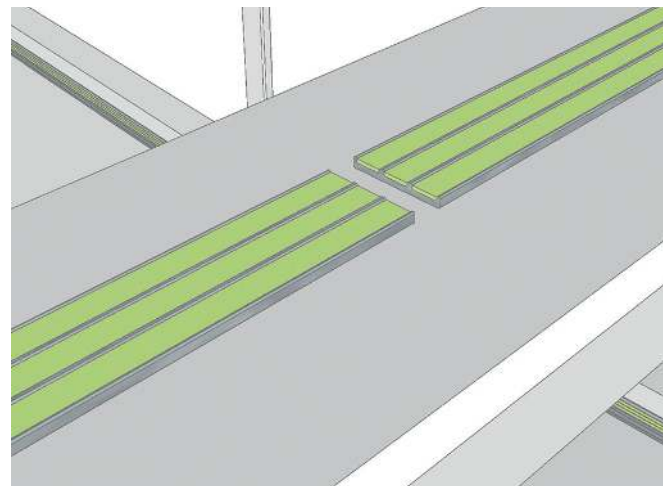

Guidance strip can be used to mark corridors, lobbies and indoor lengths of path and can be mounted either on the floor within 100mm of the wall, or on the wall within 100mm of the floor. Gaps of 3mm must be placed between strips.

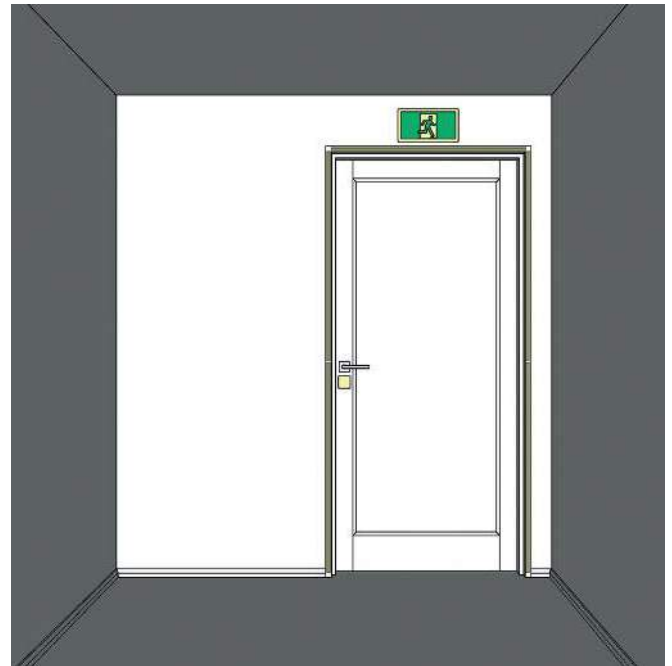
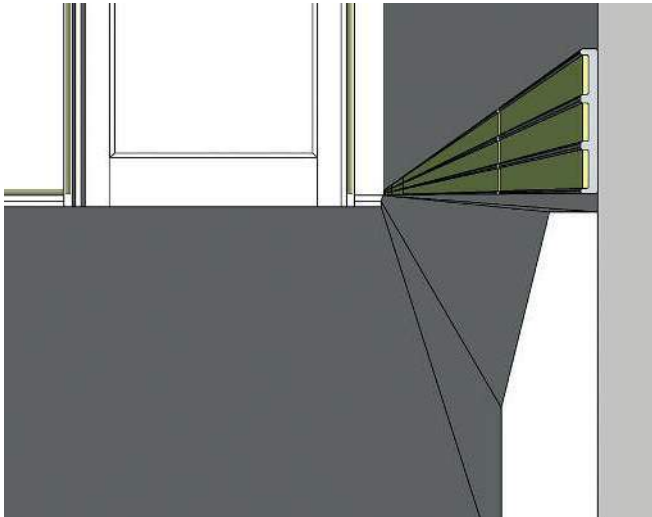

4. Mechanical Fixers (Screws or Rivets)

- For handrails in schools or other places where vandalism may occur, screws (for timber, as described above) or rivets (for metal) **MUST** be used. Install one screw/rivet 10-15mm in from each end of each strip.
- For outdoor timber installations screws **MUST** also be used so that the adhesive tape isn't able to lift if the timber distorts or absorbs moisture due to normal weather conditions. 5mm pan head screws are suitable to be screwed down firmly but not so tight that the tape squashes under the strip. Install one screw 10-15mm in from each end and one screw in the middle of each strip.
- If in doubt about the adhesion of the strips to any substrate, use screws/rivets for additional security. Install one 10-15mm in from each end and one in the middle of each strip.

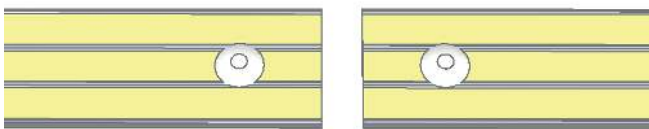

For guidance strips on handrails used in schools or public places, screws or rivets must be installed 10 – 15mm in from the end of each strip.



Ecoglo International Limited
 Email: info@ecoglo.com
www.ecoglo.com

Installation Instructions For

Handrail H Series

Wall Mounted and Freestanding
Round Handrails

Ecoglo markers are to be installed only where there will be sufficient natural or artificial light to keep them charged whenever the building is occupied.

If unsure, contact Ecoglo



1. Preparation of Surface

- Thoroughly clean the surface with an industrial strength cleaner.
- Remove any loose paint or sealant and then allow the surface to dry.
- Handrail must be dry



2. Alignment

- To ensure the Ecoglo Handrail Strip is installed in line, place a string line, slightly off centre, from the top end of the handrail to the bottom.
- This will serve as a guide for where to place each strip accurately onto the rail.



3. Placing Strip onto Handrail

- Remove the backing paper from the tape
- Line up the outside edge with the string line. The strip should be positioned approximately 50mm from the end of the handrail.
- Press firmly down.
- Repeat the above steps for the full length of the handrail leaving a 3mm gap between each length of handrail.



- If the overall length of the handrail is longer than 1 metre as supplied, then the 1 metre lengths should be placed at each end of the handrail and a separate unit should be measured and cut for the middle section.
- Following any cutting of the product, ensure edges are filed smooth and rounded.



4. Mechanical Fixers (screws or rivets)

- For handrails in schools or other places where vandalism may occur, screws (for timber, as described above) or rivets (for metal) MUST be used. Install one screw/rivet 10-15mm in from each end of each H series strip.
- For outdoor timber installations screws MUST also be used so that the adhesive tape isn't able to lift if the timber distorts or absorbs moisture due to normal weather conditions. 5mm pan head screws are suitable to be screwed down firmly but not so tight that the tape squashes under the strip. Install one screw 10-15mm in from each end and one screw in the middle of each H series strip.
- If in doubt about the adhesion of the strips to any substrate, use screws/rivets for additional security. Install one 10-15mm in from each end and one in the middle of each H series strip.

Note: Flat Handrails (applies to indoor installations only)

- Ecoglo G3-001 or G6-003 can be used on indoor handrails that have flat tops. The same method of installation applies.



Note: Under no circumstances, should handrail product be installed on or around a curve. This includes bends at each end of the handrail.

Installation Instructions For

Path Markers T-Series

Concrete and Timber

Ecoglo markers are to be installed only where there will be sufficient natural or artificial light to keep them charged whenever the building is occupied.

If unsure, contact Ecoglo



Path Markers T-Series Concrete and Timber

1. Preparation of Surface

- Thoroughly clean the surface with industrial strength cleaner if necessary.
- Remove any loose paint or sealant and then allow surface to dry.
- If painted or coated check that the adhesive is compatible with the paint or seal coating*. IF IN DOUBT REMOVE COATING.

Note: Installation onto Concrete Surfaces

It is important to use adhesive only for concrete installations. The adhesive will allow some movement to compensate for thermal contraction and expansion and will provide durable adhesion to the concrete substrate.

** Where adhesive only installation is preferred on surfaces that have a sealer applied (eg exposed aggregate and some tiles) a test patch should be laid and allowed to temperature cycle over a minimum of 14 days to ensure a good bond is achieved. If the adhesive does not hold then mechanical fixers should be used. If mechanical fixing is not practical due to potential damage to the substrate please contact Ecoglo.*

2. Alignment of the Path Markers

- Mark the position where the path marker is to be placed using a chalk line if necessary to ensure the line is straight.

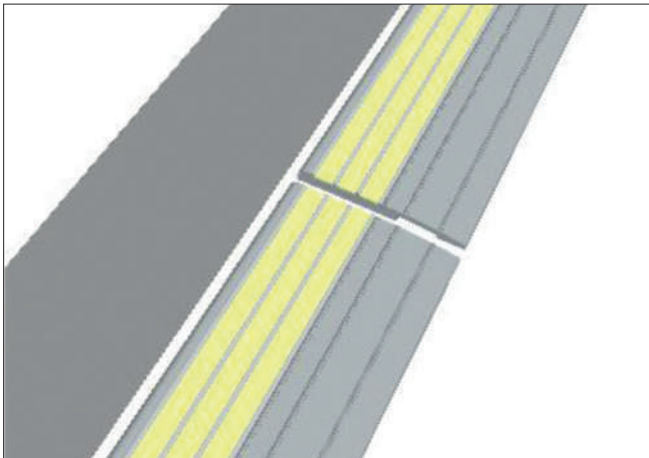

Note: The Path Markers come in 1m lengths. A 3mm expansion/drainage gap must be left between lengths. Markers can be cut with a hand-saw or drop-saw to suit.

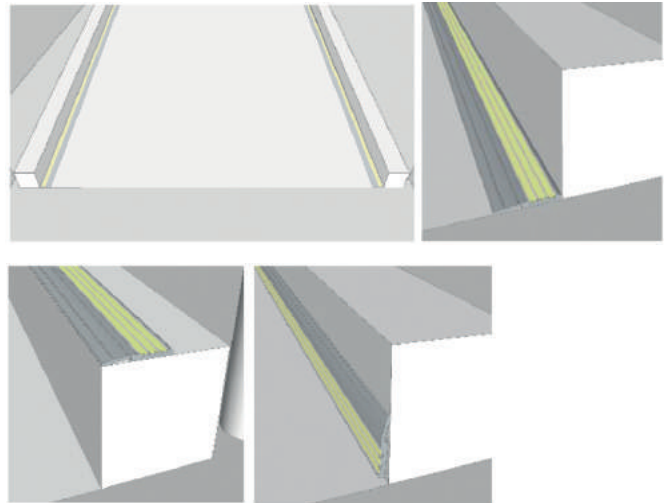

The Path Marker installed in various positions on a ramp.

3. Timber Installation

- Place the path marker in position, lining it up with any markings.
- Pre-drill a pilot hole in the timber if necessary.
- Tighten the screws firmly using a battery drill.

4. Concrete Installation

- Lay a 3mm bead of polyurethane adhesive (either Wurth KD Bond and Seal or Bostik Seal n Flex FC) in a wave pattern over the full length of widest part on the underside of the marker.
- Place the path marker firmly onto the substrate ensuring it is straight.

Adhesive Usage:

T5-101 - 25 metres per 600ml
T6-101 - 30 metres per 600ml

Ecoglo can supply Wurth KD Bond and Seal in 600ml Sausage form with Applicator Gun.

5. Curing of Adhesive

- Use an alcohol wipe to remove any spillover of adhesive.
- Allow approximately 24 hours for adhesive to cure.

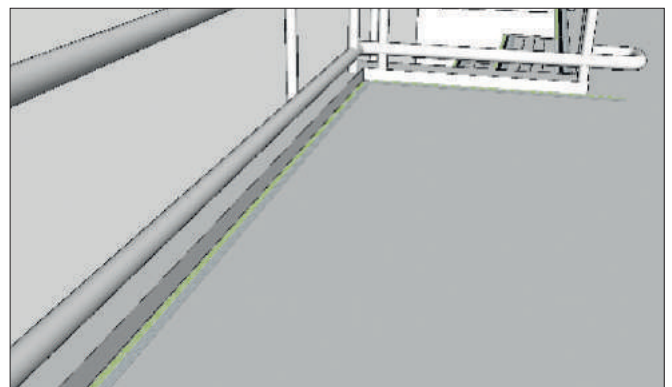

The Path Marker installed adjacent to wall.



Installation Instructions For

Hazard Tape UL-HZ2518
UL-HZ2503

Flat Surfaces

Ecoglo markers are to be installed only where there will be sufficient natural or artificial light to keep them charged whenever the building is occupied.

If unsure, contact Ecoglo

Ecoglo International Limited
Email: info@ecoglo.com
www.ecoglo.com



Installation Instructions for Hazard Tape UL-HZ2518 and UL-HZ2503

Ecoglo recommended UL-HZ2518 and UL-HZ2503

Hazard Tape can be installed successfully on most clean, dry, smooth surfaces. Common applications for the hazard tape include obstacles, pipes, and firefighting equipment which extends into the egress path.

Note: This tape is for indoor use only.

Users should test the tape in a small area for suitability and satisfactory adherence to the installation surface prior to completing full installation.

Preparation of Surface

- The installation surface **MUST** be smooth.
- Thoroughly clean the surface with an industrial strength cleaner, if necessary, to remove any surface contaminants such as dust, dirt, grease etc.
- Loose paint must be removed from painted surfaces.
- Allow the surface to dry.
- If the surface has been painted or coated, check that adhesive is compatible with the paint or seal coating.

Application (UL-HZ2518)

Applying the photoluminescent hazard tape

- **Do not stretch the tape when applying to the installation surface.**
- Apply the hazard tape by removing a few centimetres of the liner and pressing the tape to the installation surface.
- Firmly roll or rub the tape in the direction which it is being applied, removing as much liner as is required to complete installation.
- Repeat rubbing or rolling as necessary to ensure that the tape has completely conformed to the surface.

Application (UL-HZ2503)

Step 1. Applying the adhesive tape

- **Do not stretch the tape when applying to the installation surface.**
- Apply the adhesive tape by removing a few centimetres of the liner and pressing the tape to the installation surface.
- Firmly roll or rub the tape in the direction which it is being applied, removing as much liner as is required to complete installation.
- Repeat rubbing or rolling as necessary to ensure that the tape has completely conformed to the surface.

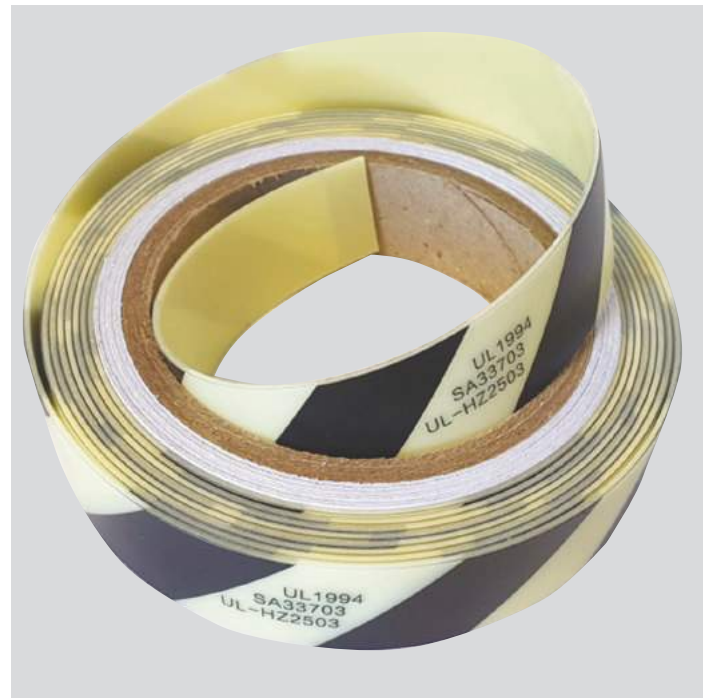

Step 2. Applying the photoluminescent hazard tape

- **Do not stretch the tape when applying to the adhesive tape.**
- Apply the hazard tape by removing a few centimetres of the liner and pressing the tape to the adhesive tape.
- Firmly roll or rub the tape in the direction which it is being applied, removing as much liner as is required to complete installation.
- Repeat rubbing or rolling as necessary to ensure that the hazard tape has completely adhered to the adhesive tape.



Installation Instructions For

Signs (Pre-fitted release tape)

(Including Floor Identification Signs and Door Handle Markers)

Surface Mounted Signs

Ecoglo signs are to be installed only where there will be sufficient natural or artificial light to keep them charged whenever the building is occupied.

If unsure, contact Ecoglo

Ecoglo International Limited
Email: info@ecoglo.com
www.ecoglo.com



Installation Instructions for Signs (Pre-fitted release tape)

1. Preparation of Surface

- Thoroughly clean the surface with industrial strength cleaner if necessary.
- Remove any loose paint or sealant then allow surface to dry.

2. Positioning of Signs

- Mark position on the door or wall where sign is to be placed.

Note:

Floor Identification signs – the mounting height must be in accordance with local and national codes.

3. Placement of Signs

- Peel the protective layer from the back of the sign to expose the adhesive ensuring nothing comes into contact with it.
- Line the sign up with the markings you made.
- Apply pressure evenly over the sign to fix it fast to the surface.

4. Maintenance of Signs

- Regular dusting with a soft cloth or brush is recommended to keep the sign clean.
- If the sign is noticeably dirty, clean with a sponge or cloth.

See Cleaning Instructions for more detailed information.

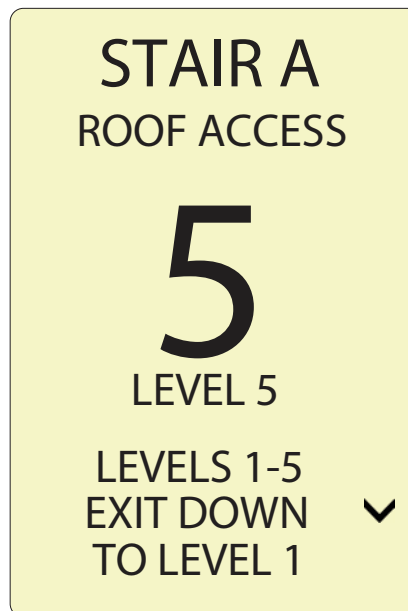



Installation Instructions For

Door Push Bar Marker UL-DHM3840

Flat Surfaces

Ecoglo markers are to be installed only where there will be sufficient natural or artificial light to keep them charged whenever the building is occupied.

If unsure, contact Ecoglo

Ecoglo International Limited
Email: info@ecoglo.com
www.ecoglo.com



Installation Instructions for Door Push Bar Marker

UL-DHM3840



Ecoglo recommended UL-DHM3840 Door Push Bar Marker comes pre-fitted with release tape, making installation a simple process.

Note: This marker is for indoor use only.

1. Surface preparation

- The installation surface MUST be smooth.
- Thoroughly clean the surface with an industrial strength cleaner, if necessary, to remove any surface contaminants such as dust, dirt, grease etc.
- Loose paint must be removed from painted surfaces.
- Allow the surface to dry.
- If the surface has been painted or coated, check that adhesive is compatible with the paint or seal coating.

2. Application

- If necessary, mark the position on the push bar where the Door Push Bar Marker is to be placed.
- Carefully peel off the release-tape backing from the marker.
- Line the marker up with any alignment marks made.
- Press the marker firmly in place to ensure even contact between the adhesive tape and the push bar.



Appendix 3

Ecoglo International Ltd

Product Test Reports

Contents	Page
UL 410 Standard for Slip Resistance of Floor Surface Material	96
AS/NZS 4586-2004, Slip Resistance Classification of New Pedestrian Surface Materials	114
AS 4586-2013, Slip Resistance Classification of New Pedestrian Surface Materials ¹	120
ASTM G155-04 Cycle 1 1000hrs, Standard Practice for Operating Xenon Arc Light Apparatus for Exposure of Nonmetallic Materials	128
ASTM B117-97 1000hrs, Standard Practice for Operating Salt Spray (Fog) Apparatus	131
ASTM D4828-94 (2003), Standard Test Methods for Practical Washability of Organic Coatings	132
ASTM D635-03, Standard Test Method for Rate of Burning and/or Extent and Time of Burning of Plastics in a Horizontal Position	133
ASTM E162-02, Standard Test Method for Surface Flammability of Materials using a Radiant Heat Energy Source	134
Bombardier Toxic Gas Generation Test SMP800-C	137
ASTM D3648-2004, Standard Practices for Measurement of Radioactivity	134
UL 1994 Standard for Luminous Egress Path Markings	140
HTC (High Temperature Curing) Test (based on AS/NZS 1580.481.1)	143

Number of pages in this package 9

CLIENT INFORMATION	
Company Name	ECOGLO INTERNATIONAL LTD.
Address	77 Kingsley St Christchurch, 8023 New Zealand

AUDIT INFORMATION:			
Description of Tests	Per Standard No.	UL 410	Edition/ Revision Date
			Third Dated October 25, 2006
[X] Tests Conducted by +			
	Aaron Messinger		<i>Aaron J. Messinger</i>
	Printed Name		Signature
[] UL Staff witnessing testing (WTDP only)			
[] Authorized Signatory (CTDP, TPTDP, TCP)		Printed Name	Signature, and include date for CTDP, TPTDP, TCP
Reviewed and accepted by qualified Project Handler			
		Printed Name	Signature

[] The following tests conducted in accordance with UL _____ were considered representative of the same tests required by Canadian Standard, _____.

TESTS TO BE CONDUCTED:			
Test No.	Done	Test Name	[] Comments/Parameters [] Tests Conducted by ++
1	11/12/2018	SLIP RESISTANCE CHARACTERISTICS: WCM	

Instructions -
 1 - When all tests are conducted by one person, name can be inserted here instead of including name on each page containing data.
 2 - When test conducted by more than one person, name of person conducting the test can be inserted next to the test name instead of including name on each page containing data. Test dates may be recorded here instead of entering test dates on the individual datasheet pages.
 3 - Indication of compliance is optional. See the datasheet for each test for compliance.
 4 - Link to separate data files for a test can be inserted here. The link must be to a server that is accessible to UL staff, that provides for backup, required retention periods and a path, including file name that does not change and result in a broken link. Not applicable to DAP.

If noncompliant test results are obtained, provide this data to a qualified project handler for further processing.

Special Instructions -

Unless specified otherwise in the individual Methods, the tests shall be conducted under the following ambient conditions. Confirmation of these conditions shall be recorded at the time the test is conducted.

Ambient Temperature, C 23 ± 2 Relative Humidity, % 50 ± 4 Barometric Pressure, mBar ±

No general environmental conditions are specified in the Standard(s) or have been identified that could affect the test results or measurements.

RISK ANALYSIS RELATED TO TESTING PERFORMANCE:

The following types of risks have been identified. Take necessary precautions. This list is not all inclusive.

<input type="checkbox"/> Electric shock	<input type="checkbox"/> Radiation
<input type="checkbox"/> Energy related hazards	<input type="checkbox"/> Chemical hazards
<input type="checkbox"/> Fire	<input type="checkbox"/> Noise
<input type="checkbox"/> Heat related hazards	<input type="checkbox"/> Vibration
<input type="checkbox"/> Mechanical	<input checked="" type="checkbox"/> Other (Specify) Slip Resistance

TEST LOCATION: (To be completed by Staff Conducting the Testing)	
<input checked="" type="checkbox"/> UL or Affiliate	<input type="checkbox"/> WTDP <input type="checkbox"/> TPTDP
Company Name: UL Verification Services.	
Address: Holland MI.	

TEST EQUIPMENT INFORMATION

UL test equipment information is recorded on Meter Use.

UL test equipment information is recorded on <<insert location and local laboratory equipment system identification.>>

Inst. ID No.	Instrument Type	Test Number +, Test Title or Conditioning	Function /Range	Last Cal. Date	Next Cal. Date

+ - If Test Number is used, the Test Number must be identified on the data sheet pages or on the Data Sheet Package cover page.

The following additional information is required when using client's or rented equipment. The Inst. ID No. below corresponds to the Inst. ID No. above.

Inst. ID No.	Make/Model/Serial Number/Asset No.

Test equipment information is recorded on UL's Laboratory Project Management (LPM)/Laboratory Equipment Management (LEM) database. (This statement may be selected only if datasheets are completed electronically at a UL facility).

TEST SAMPLE IDENTIFICATION:

The table below is provided to provide correlation of sample numbers to specific product related information. Refer to this table when a test identifies a test sample by "Sample No." only.

Sample Card No.	Date Received	<input type="checkbox"/> Test No.	Sample No.	Manufacturer, Product Identification and Ratings
1856715	10/09/2018	1	1	ECOGLO INTERNATIONAL LTD, PL Path Marking Models E4-073 WCM
1856715	10/09/2018	1	2	ECOGLO INTERNATIONAL LTD, PL Path Marking Model E14-075 WCM

+ - If Test Number is used, the Test Number or Numbers the sample was used in must be identified on the data sheet pages or on the Data Sheet Package cover page.

Sampling Procedure -

SLIP RESISTANCE CHARACTERISTICS: (WCM)

WCM Material: Model E4-073

METHOD

[X] A sample of the material was tested as received after it was brushed or wiped clean to remove any surface contaminants.

[X] Additionally, a second sample of the material was tested after belt sanding with 1/2 (60) grit aluminum oxide paper for 1 minute and brushed or wiped clean to remove surface contaminants.

The slip resistance characteristics of the material were measured in accordance with the established and standardized practice of UL LLC and in accordance with the latest edition of the Standard for Slip Resistance of Floor Surface Materials, UL 410.

RESULTS

(As received)

Sample Orientation	Coefficient of Friction
First Quadrant	0.59
Adjacent Quadrant	0.54
180 degrees from First Quadrant	0.60
180 degrees from Adjacent Quadrant	0.54
Average	0.56

[X] The average static coefficient of friction of the four quadrants of the test sample **[was]** ~~[was not]~~ at least 0.50 and the individual static coefficients of friction **[was]** ~~[was not]~~ at least 0.45.

SLIP RESISTANCE CHARACTERISTICS: (WCM) (CONT'D)

WCM Material: Model E4-073

wide

(Belt Sanded)

Sample Orientation	Coefficient of Friction
First Quadrant	0.55
Adjacent Quadrant	0.68
180 degrees from First Quadrant	0.57
180 degrees from Adjacent Quadrant	0.69
Average	0.62

[X] The average static coefficient of friction of the four quadrants of the test sample **[was]** ~~[was not]~~ at least 0.50 and the individual static coefficients of friction **[was]** ~~[was not]~~ at least 0.45.

Note to Lab:

If the minimum and maximum run values vary by greater than 0.06, please re-conduct the test. If the second set minimum and maximum values vary greater than 0.06, please contact the engineer.

Slip Resistance Test Conditions

AMBIENT TEMPERATURE **22.5°C** Relative Humidity **49.1%**

SLIP RESISTANCE CHARACTERISTICS: (WCM)

WCM

Material: Model E14-075

METHOD

[X] A sample of the material was tested as received after it was brushed or wiped clean to remove any surface contaminants.

[X] Additionally, a second sample of the material was tested after belt sanding with 1/2 (60) grit aluminum oxide paper for 1 minute and brushed or wiped clean to remove surface contaminants.

The slip resistance characteristics of the material were measured in accordance with the established and standardized practice of UL LLC and in accordance with the latest edition of the Standard for Slip Resistance of Floor Surface Materials, UL 410.

RESULTS

(As received)

Sample Orientation	Coefficient of Friction
First Quadrant	0.64
Adjacent Quadrant	0.56
180 degrees from First Quadrant	0.68
180 degrees from Adjacent Quadrant	0.52
Average	0.60

[X] The average static coefficient of friction of the four quadrants of the test sample **[was]** ~~[was not]~~ at least 0.50 and the individual static coefficients of friction **[was]** ~~[was not]~~ at least 0.45.

SLIP RESISTANCE CHARACTERISTICS: (WCM) (CONT'D)

Material: Model E14-075

(Belt Sanded)

Sample Orientation	Coefficient of Friction
First Quadrant	0.55
Adjacent Quadrant	0.53
180 degrees from First Quadrant	0.52
180 degrees from Adjacent Quadrant	0.55
Average	0.53

[X] The average static coefficient of friction of the four quadrants of the test sample **[was]** ~~[was not]~~ at least 0.50 and the individual static coefficients of friction **[was]** ~~[was not]~~ at least 0.45.

Note to Lab:

If the minimum and maximum run values vary by greater than 0.06, please re-conduct the test. If the second set minimum and maximum values vary greater than 0.06, please contact the engineer.

Slip Resistance Test Conditions

AMBIENT TEMPERATURE **22.5°C** Relative Humidity **49.1%**

Project No. 4788667654
LABORATORY DATA PACKAGE

File SA

Page 9
Date _____

END OF DATASHEET PACKAGE. THIS PAGE INTENTIONALLY LEFT BLANK

ULS-00410-IMET-DataSheet-2001
Form Page 9

Form Issued: 2002-10-28
Form Revised: 2012-05-16

Copyright © 2012 UL LLC

Only those products bearing the UL Mark should be considered as being covered by UL.

Number of pages in this package 9

CLIENT INFORMATION	
Company Name	ECOGLO INTERNATIONAL LTD.
Address	77 Kingsley St Christchurch, 8023 New Zealand

AUDIT INFORMATION:			
Description of Tests	Per Standard No.	UL 410	Edition/ Revision Date
			Third Dated October 25, 2006
[X] Tests Conducted by +			
	Aaron Messinger		<i>Aaron J. Messinger</i>
	Printed Name		Signature
[] UL Staff witnessing testing (WTDP only)			
[] Authorized Signatory (CTDP, TPTDP, TCP)			
	Printed Name		Signature, and include date for CTDP, TPTDP, TCP
Reviewed and accepted by qualified Project Handler			
	Printed Name		Signature

[] The following tests conducted in accordance with UL 410 were considered representative of the same tests required by Canadian Standard, _____.

TESTS TO BE CONDUCTED:			
Test No.	Done	Test Name	[] Comments/Parameters [] Tests Conducted by ++
1	01/29/2020	SLIP RESISTANCE CHARACTERISTICS: WCM	

Instructions -

- 1 - When all tests are conducted by one person, name can be inserted here instead of including name on each page containing data.
- 2 - When test conducted by more than one person, name of person conducting the test can be inserted next to the test name instead of including name on each page containing data. Test dates may be recorded here instead of entering test dates on the individual datasheet pages.
- 3 - Indication of compliance is optional. See the datasheet for each test for compliance.
- 4 - Link to separate data files for a test can be inserted here. The link must be to a server that is accessible to UL staff, that provides for backup, required retention periods and a path, including file name that does not change and result in a broken link. Not applicable to DAP.

If noncompliant test results are obtained, provide this data to a qualified project handler for further processing.

Special Instructions -

Unless specified otherwise in the individual Methods, the tests shall be conducted under the following ambient conditions. Confirmation of these conditions shall be recorded at the time the test is conducted.

Ambient Temperature, C 23 ± 2 Relative Humidity, % 50 ± 4 Barometric Pressure, mBar ±

No general environmental conditions are specified in the Standard(s) or have been identified that could affect the test results or measurements.

RISK ANALYSIS RELATED TO TESTING PERFORMANCE:

The following types of risks have been identified. Take necessary precautions. This list is not all inclusive.

<input type="checkbox"/> Electric shock	<input type="checkbox"/> Radiation
<input type="checkbox"/> Energy related hazards	<input type="checkbox"/> Chemical hazards
<input type="checkbox"/> Fire	<input type="checkbox"/> Noise
<input type="checkbox"/> Heat related hazards	<input type="checkbox"/> Vibration
<input type="checkbox"/> Mechanical	<input checked="" type="checkbox"/> Other (Specify) Slip Resistance

TEST LOCATION: (To be completed by Staff Conducting the Testing)	
<input checked="" type="checkbox"/> UL or Affiliate	<input type="checkbox"/> WTDP <input type="checkbox"/> TPTDP
Company Name: UL Verification Services.	
Address: Holland MI.	

TEST EQUIPMENT INFORMATION

UL test equipment information is recorded on Meter Use.

UL test equipment information is recorded on <<insert location and local laboratory equipment system identification.>>

Inst. ID No.	Instrument Type	Test Number +, Test Title or Conditioning	Function /Range	Last Cal. Date	Next Cal. Date

+ - If Test Number is used, the Test Number must be identified on the data sheet pages or on the Data Sheet Package cover page.

The following additional information is required when using client's or rented equipment. The Inst. ID No. below corresponds to the Inst. ID No. above.

Inst. ID No.	Make/Model/Serial Number/Asset No.

Test equipment information is recorded on UL's Laboratory Project Management (LPM)/Laboratory Equipment Management (LEM) database. (This statement may be selected only if datasheets are completed electronically at a UL facility).

TEST SAMPLE IDENTIFICATION:

The table below is provided to provide correlation of sample numbers to specific product related information. Refer to this table when a test identifies a test sample by "Sample No." only.

Sample Card No.	Date Received	[] Test No.	Sample No.	Manufacturer, Product Identification and Ratings
283399	01/28/2020	1	1	ECOGLO INTERNATIONAL LTD, PL Path Marking Models G6-003 Alternate Model Names G6003, G5-001, G5001 WCM

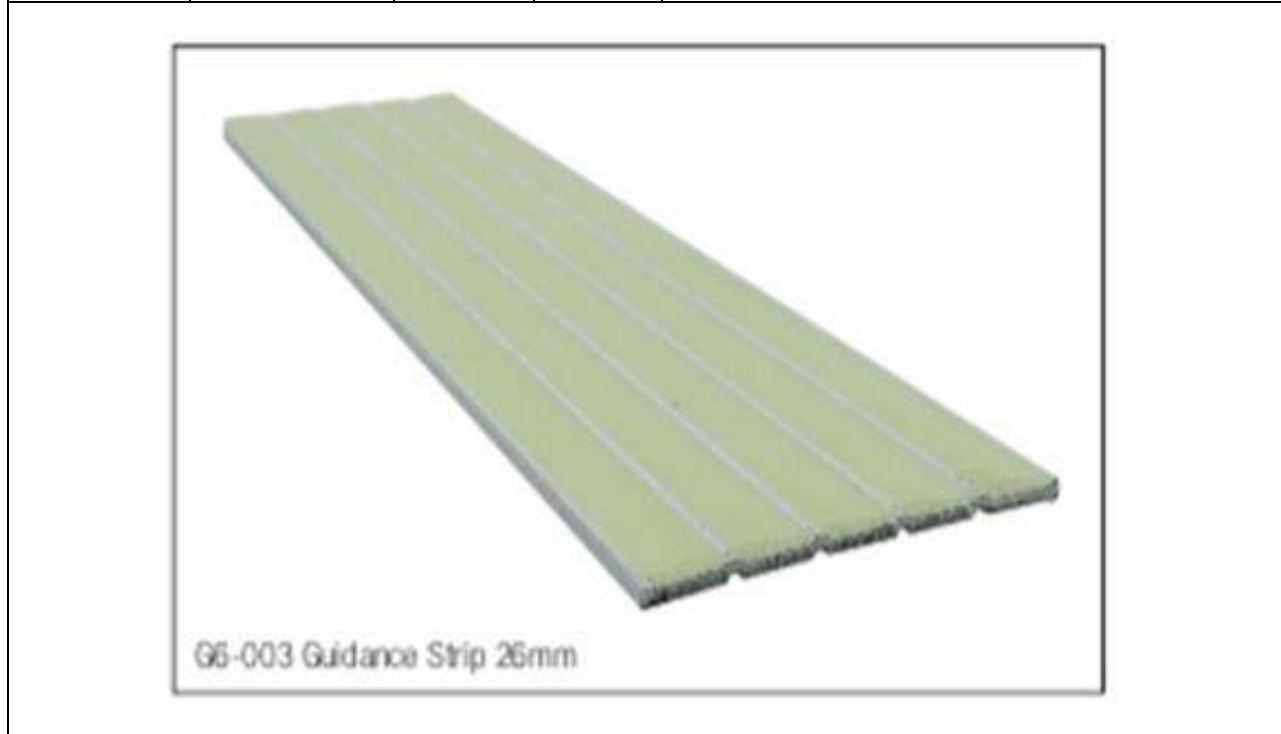

+ - If Test Number is used, the Test Number or Numbers the sample was used in must be identified on the data sheet pages or on the Data Sheet Package cover page.

[] Sampling Procedure -

SLIP RESISTANCE CHARACTERISTICS: (WCM)

WCM Material: Model G6-003

METHOD

[X] A sample of the material was tested as received after it was brushed or wiped clean to remove any surface contaminants.

[X] Additionally, a second sample of the material was tested after belt sanding with 1/2 (60) grit aluminum oxide paper for 1 minute and brushed or wiped clean to remove surface contaminants.

The slip resistance characteristics of the material were measured in accordance with the established and standardized practice of UL LLC and in accordance with the latest edition of the Standard for Slip Resistance of Floor Surface Materials, UL 410.

RESULTS

(As received)

Sample Orientation	Coefficient of Friction
First Quadrant	0.59
Adjacent Quadrant	0.54
180 degrees from First Quadrant	0.60
180 degrees from Adjacent Quadrant	0.54
Average	0.56

[X] The average static coefficient of friction of the four quadrants of the test sample **[was]** ~~[was not]~~ at least 0.50 and the individual static coefficients of friction **[was]** ~~[was not]~~ at least 0.45.

SLIP RESISTANCE CHARACTERISTICS: (WCM) (CONT'D)

WCM Material: Model E4-073

wide

(Belt Sanded)

Sample Orientation	Coefficient of Friction
First Quadrant	0.55
Adjacent Quadrant	0.68
180 degrees from First Quadrant	0.57
180 degrees from Adjacent Quadrant	0.69
Average	0.62

[X] The average static coefficient of friction of the four quadrants of the test sample **[was]** ~~[was not]~~ at least 0.50 and the individual static coefficients of friction **[was]** ~~[was not]~~ at least 0.45.

Note to Lab:

If the minimum and maximum run values vary by greater than 0.06, please re-conduct the test. If the second set minimum and maximum values vary greater than 0.06, please contact the engineer.

Slip Resistance Test Conditions

AMBIENT TEMPERATURE **23.2°C** Relative Humidity **49.6%**

SLIP RESISTANCE CHARACTERISTICS: (WCM)

WCM

Material: Model E14-075

METHOD

[X] A sample of the material was tested as received after it was brushed or wiped clean to remove any surface contaminants.

[X] Additionally, a second sample of the material was tested after belt sanding with 1/2 (60) grit aluminum oxide paper for 1 minute and brushed or wiped clean to remove surface contaminants.

The slip resistance characteristics of the material were measured in accordance with the established and standardized practice of UL LLC and in accordance with the latest edition of the Standard for Slip Resistance of Floor Surface Materials, UL 410.

RESULTS

(As received)

Sample Orientation	Coefficient of Friction
First Quadrant	0.64
Adjacent Quadrant	0.56
180 degrees from First Quadrant	0.68
180 degrees from Adjacent Quadrant	0.52
Average	0.60

[X] The average static coefficient of friction of the four quadrants of the test sample **[was]** ~~[was not]~~ at least 0.50 and the individual static coefficients of friction **[was]** ~~[was not]~~ at least 0.45.

SLIP RESISTANCE CHARACTERISTICS: (WCM) (CONT'D)

Material: Model E14-075

(Belt Sanded)

Sample Orientation	Coefficient of Friction
First Quadrant	0.55
Adjacent Quadrant	0.53
180 degrees from First Quadrant	0.52
180 degrees from Adjacent Quadrant	0.55
Average	0.53

[X] The average static coefficient of friction of the four quadrants of the test sample **[was]** ~~[was not]~~ at least 0.50 and the individual static coefficients of friction **[was]** ~~[was not]~~ at least 0.45.

Note to Lab:

If the minimum and maximum run values vary by greater than 0.06, please re-conduct the test. If the second set minimum and maximum values vary greater than 0.06, please contact the engineer.

Slip Resistance Test Conditions

AMBIENT TEMPERATURE **22.5°C** Relative Humidity **49.1%**

Project No. 4789277791
LABORATORY DATA PACKAGE

File SA45391

Page 9
Date _____

END OF DATASHEET PACKAGE. THIS PAGE INTENTIONALLY LEFT BLANK

ULS-00410-IMET-DataSheet-2001
Form Page 9

Form Issued: 2002-10-28
Form Revised: 2012-05-16

Copyright © 2012 UL LLC

Only those products bearing the UL Mark should be considered as being covered by UL.

**ATTAR TEST REPORT NUMBER: 08/2689**

This document is issued in accordance with NATA's accreditation requirements. The results of the tests, calibrations and/or measurements included in this document are traceable to Australian/national standards. Accredited for compliance with ISO/IEC 17025.

27 October 2008

Total Pages: 2**OIL-WET RAMP SLIP RESISTANCE**

Job No: M08/2689

Prepared for:	Ecoglo Ltd P.O. Box 8654 CHRISTCHURCH NEW ZEALAND	
Attention:	Mr. Mark Watson	
Test Site:	ATTAR, Unit 12, 134 Springvale Road, Springvale.	
Test Date:	23 October 2008	
Manufacturer:	Ecoglo Ltd	
Test Specimen, Size & Quantity Received:	Ecoglo N1070 slip resistant strip, 51x600 mm, 22 off supplied.	
Sampling & Direction of Testing:	Sampling conducted by client. Testing conducted as shown in Figure 1.	
Test Personnel:	Simon Langdon & Callum Oakey	
Preparation:	As received, fastened to 1200x600x12 mm particle board for testing.	
Joint Width:	N/A	
Air Temperature:	20°C	
Test Standard:	AS/NZS 4586 - 2004 Slip resistance classification of new pedestrian surface materials – Appendix D.	
Surface Structure :	Structured.	
Classification Criteria: (TABLE D3 in AS/NZS 4586- 2004)	Corrected Mean Overall Acceptance Angle	Slip Resistance Assessment Group
	6° to 10°	R9
	Over 10° to 19°	R10
	Over 19° to 27°	R11
	Over 27° to 35°	R12
	Over 35°	R13
Displacement Space:	Not Measured	
Displacement Space Assessment Group:	N/A	
Mean Overall Acceptance Angle:	33.6°	
Slip Resistance Assessment Group:	R12	

These results apply only to the specimens tested and it is recommended that before selection of flooring or paving materials the effect of service conditions, including maintenance procedures and wear on their slip-resistance be checked.

NOTE: Any specimens supplied will be disposed of in two (2) months time, unless otherwise instructed.

ATTAR

Simon Langdon
Engineering Technician
Approved Signatory

This report may not be reproduced except in its entirety.



Figure 1: General view of Ecoglo N1070 slip resistant strips fastened to particle board for testing. Arrow indicates direction of testing..

**ATTAR TEST REPORT NUMBER: 07/1890.1**

This document is issued in accordance with NATA's accreditation requirements. The results of the tests, calibrations and/or measurements included in this document are traceable to Australian/national standards. Accredited for compliance with ISO/IEC 17025.

27 November 2007

Total Pages: 2**DRY SLIP RESISTANCE**

Job No: M07/1890

Prepared for:	Ecoglo Ltd. 77 Kingsley Street CHRISTCHURCH 8002 NEW ZEALAND		
Attention:	Mr. Mark Watson		
Test Site:	ATTAR, Unit 27, 134 Springvale Road, Springvale.		
Test Date:	26 November 2007		
Test Specimens, Size and Quantity:	4 off Ecoglo N1070 50x250 mm black carbide strips mounted to 200x250 mm aluminium backing plate, 5 off supplied.		
Sampling and Direction of Test:	Sampling conducted by client. Testing conducted as per Section A4.3.3 and Figure A5 of AS/NZS 4586:2004 as shown in Figure 1.		
Test Personnel:	Simon Langdon		
Preparation:	As received.		
Fixed/Unfixed:	Unfixed.		
Air Temperature:	23°C		
Test Equipment:	Tortus Floor Friction Tester; Tortus Model Mk 2 (with integral printer), Serial No: 233.		
Test Standard:	AS/NZS 4586 - 2004 Slip resistance classification of new pedestrian surface materials – Appendix B.		
Slider Rubber:	Slider 96 (Four S) Batch No. 18		
Classification Criteria:	Refer Appendix 1 – Classification Criteria, attached.		
Dynamic Coefficient of Friction	Run 1	Run 2	Mean Rounded to 0.05
	0.91	0.93	0.90
Classification:	F		

These results apply only to the specimens tested and it is recommended that before selection of flooring or paving materials the effect of service conditions, including maintenance procedures and wear on their slip-resistance be checked.

NOTE: Any specimens supplied will be disposed of in two (2) months time, unless otherwise instructed.

ATTAR

Marcus Braché
Senior Engineering Technician

Simon Langdon
Engineering Technician

This report may not be reproduced except in its entirety.

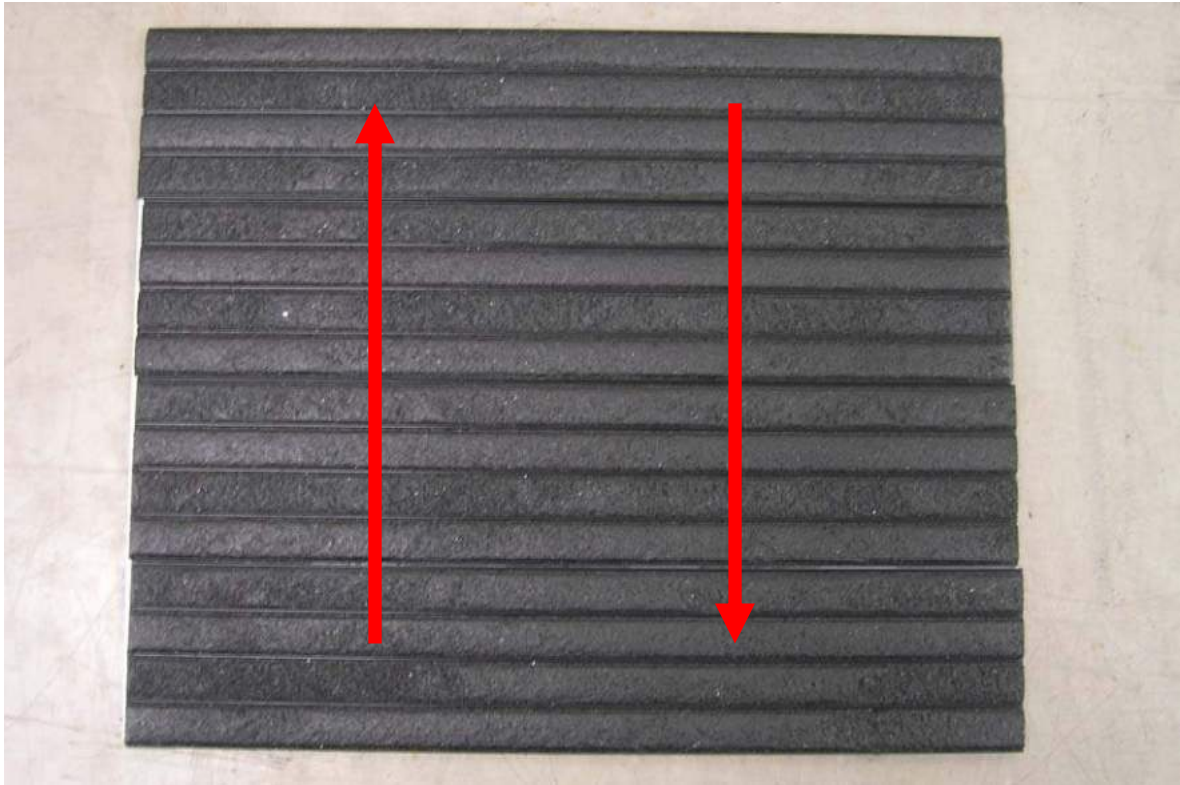

Figure 1: General view of Ecoglo N1070 product. Arrows indicate direction of dry testing.

**ATTAR TEST REPORT NUMBER: 07/1890.2**

This document is issued in accordance with NATA's accreditation requirements. The results of the tests, calibrations and/or measurements included in this document are traceable to Australian/national standards. Accredited for compliance with ISO/IEC 17025.

27 November 2007

Total Pages: 2**WET SLIP RESISTANCE**

Job No: M07/1890

Prepared for:	Ecoglo Ltd. 77 Kingsley Street CHRISTCHURCH 8002 NEW ZEALAND					
Attention:	Mr. Mark Watson					
Test Site:	ATTAR, Unit 27, 134 Springvale Road, Springvale.					
Test Date:	26 November 2007					
Test Specimens, Size & Quantity:	4 off Ecoglo N1070 50x250 mm black carbide strips mounted to 200x250 mm aluminium backing plate, 5 off supplied.					
Sampling & Direction of Testing:	Sampling conducted by client. Testing conducted as per Section A4.3.3 and Figure A5 of AS/NZS 4586:2004 as shown in Figure 1.					
Test Personnel:	Simon Langdon					
Preparation:	As received.					
Fixed/Unfixed:	Unfixed.					
Air Temperature:	23°C					
Test Equipment:	Stanley Skid Resistance Tester (Pendulum) Serial Number 0320, Calibrated 11/04/2007.					
Test Standard:	AS/NZS 4586 - 2004 Slip resistance classification of new pedestrian surface materials – Appendix A.					
Slider Rubber:	Slider 96 (Four S) Batch No. 22					
Classification Criteria:	Refer Appendix 1 – Classification Criteria, attached.					
British Pendulum Number	Specimen Number					Mean
	1	2	3	4	5	
	80	76	78	81	74	78
Classification:	V					

These results apply only to the specimens tested and it is recommended that before selection of flooring or paving materials the effect of service conditions, including maintenance procedures and wear on their slip-resistance be checked.

NOTE: Any specimens supplied will be disposed of in two (2) months time, unless otherwise instructed.

ATTAR

Marcus Braché
Senior Engineering Technician

Simon Langdon
Engineering Technician

This report may not be reproduced except in its entirety.



Figure 1: General view of Ecoglo N1070 product. Arrows indicate direction of wet testing.

**ATTAR TEST REPORT NUMBER: 14/8445**

The results of the tests, calibrations and/or measurements included in this document are traceable to Australian/national standards.
Accredited for compliance with ISO/IEC 17025.
Accreditation Number: 2735

21 November 2014

Total Pages: 2**WET PENDULUM SLIP RESISTANCE**

Job No: M14/8445

Prepared for:	Ecoglo International Ltd. 77 Kingsley Street CHRISTCHURCH 8023 NEW ZEALAND					
Attention:	Mark Watson					
Test Site:	ATTAR, Unit 1, 64 Bridge Road, Keysborough.					
Test Date:	20 November 2014					
Test Specimens, Size & Quantity:	Ecoglo N3-070 contrast strip stair nosing, 150x51 mm, 15 off supplied. Refer to Figure 1.					
Sampling & Direction of Testing:	Sampling conducted by client. Testing conducted perpendicular to profiled pattern (direction of pedestrian movement on stair descent). Refer to Figure 1.					
Test Personnel:	Marcus Braché					
Preparation:	Stair nosing strips fixed to plywood board. Washed with water and methylated spirits, rinsed with water, then dried.					
Fixed/Unfixed:	Fixed.					
Air Temperature:	22°C					
Test Equipment:	Munro Stanley Skid Resistance Tester (Pendulum) Serial Number 0320, Calibrated 16/10/2013.					
Test Standard:	AS 4586: 2013 Slip resistance classification of new pedestrian surface materials – Appendix A.					
Slider Rubber:	Slider 96 Batch No. #53 prepared on P400 & 3µm lapping film.					
Classification Criteria:	Refer to Classification Criteria, attached as Appendix 1.					
British Pendulum Number	Specimen Number					SRV
	1	2	3	4	5	
	81	86	81	83	80	82
Classification:	P5					

These results apply only to the specimens tested and it is recommended that before selection of flooring or paving materials the effect of service conditions, including maintenance procedures and wear on their slip-resistance be checked.

NOTE: Any specimens supplied will be disposed of in two (2) months time, unless otherwise instructed.

ATTAR

Marcus Braché
Senior Engineering Technician
Approved Signatory

This report may not be reproduced except in its entirety.

Page 1 of 2

ATTAR TEST REPORT NUMBER: 14/8445

21 November 2014

Total Pages: 2



Figure 1: Ecoglo N3-070 contrast strip.
Highlighted area and arrow indicates contact area and test direction.



WET PENDULUM SLIP RESISTANCE TEST

Ecoglo Guidance Strip G6-003

Prepared for: Ecoglo International Ltd
Mark Watson
77 Kingsley Street
CHRISTCHURCH NZ 8240

Specimen Description: Ecoglo Guidance Strip G6-003, 26x300 mm.

No. of Specimens: 5 off (Sampling Conducted by Client)

Specimen Preparation: Washed with water and pH neutral detergent, rinsed then dried.

Test Condition & Slope: Unfixed, N/A

Test Direction: Test conducted at approximately 10° offset to the direction pedestrian movement on stair descent.

Air Temperature: 21°C

Test Standard: AS 4586:2013 Slip resistance classification of new pedestrian surface materials, Appendix A - Wet Pendulum Test

Test Location: ATTAR Unit 1, 64 Bridge Road, Keysborough.

Test Date: 11 December 2019

Test Equipment: Munro Stanley Pendulum Skid Resistance Tester Serial Number 0320, Calibrated 03/05/2018.

Slider Rubber: Slider 96 Batch No. #92 prepared on P400 & 3µm lapping film.

Test Personnel: Awel Guled

Specimen Number	1	2	3	4	5
Mean British Pendulum Number (BPN)	39	39	40	40	38
Slip Resistance Value (SRV)	39				
Classification	P3				

These results apply only to the specimens tested and it is recommended that before selection of flooring or paving materials the effect of service conditions, including maintenance procedures and wear on their slip resistance be checked. Where alternatives are permitted by the standard, the choice of rubber slider used may also influence the test results obtained.

Reviewed By:



Awel Guled
Compliance and Test Technician
Approved Signatory



Dale Siegle
Compliance and Test Technician
Approved Signatory

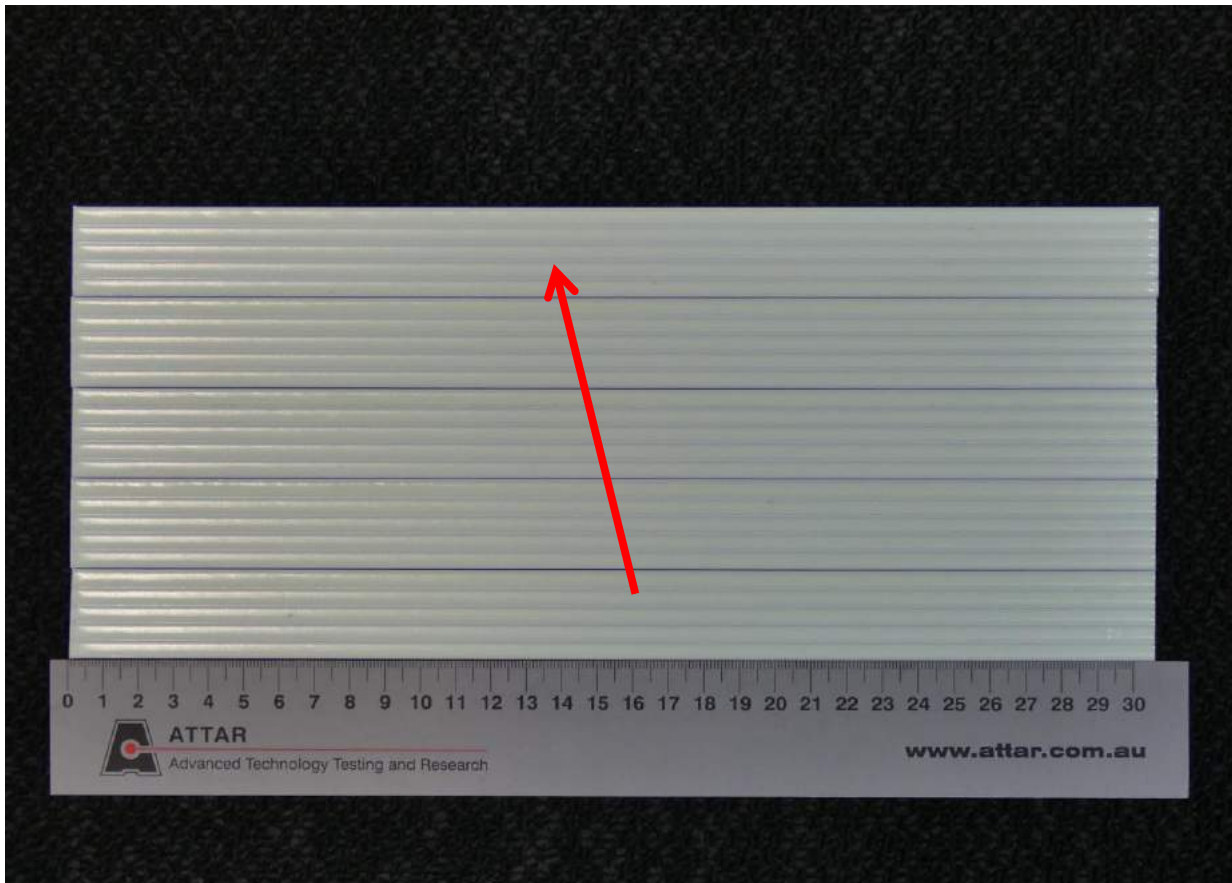

Figure 1: Ecoglo Guidance Strip G6-003
Arrow indicates direction of testing

CLASSIFICATION CRITERIA – AS 4586 – 2013
Wet Pendulum Test - Appendix A

Slip resistance

When this Standard is used for the testing and classification of the slip resistance of carpets (or carpet-like products) in potentially wet locations, the carpet shall be tested using the wet pendulum test method set out in Appendix A of AS 4586, and shall be reported as such.

When this AS 4586 is used for the testing and classification of the slip resistance of carpets in dry locations, the test shall be carried out in the dry condition using the pendulum test method set out in Appendix A of AS 4586, modified in accordance with Paragraph A2, and shall be reported as such.

The ‘dry floor friction’ test method in Appendix B of AS 4586 is not suitable for heavily profiled surfaces or carpets.

Compliance

The surface shall comply with the stated classification for the test method and test rubber that is nominated and declared by the manufacturer or supplier.

**TABLE 2: CLASSIFICATION OF PEDESTRIAN SURFACE MATERIALS
 ACCORDING TO THE AS 4586 WET PENDULUM TEST**

Class	Pendulum SRV (see Note 1)	
	Slider 96	Slider 55
P5	>54	>44
P4	45-54	40-44
P3	35-44	35-39
P2	25-34	20-34
P1	12-24	<20
P0	<12	

- NOTES:
- 1 While Slider 96 or Slider 55 rubbers may be used, the test report shall specify the rubber that was used.
 - 2 It is expected that these surfaces will have greater slip resistance when dry.
 - 3 SDV may be calculated by using the tables that are given in Appendix F of AS 4586, and the minimum SRV that is considered appropriate for a level surface (see examples given in Appendix F of AS 4586).

Means of demonstrating compliance

Pedestrian surfaces that are classified in accordance with Table 2 shall meet the following criteria:

- (a) The mean test results shall be as follows:
 - (i) For the classifications in Table 2, the mean of the test results shall be—
 - (A) within the relevant criteria set out in the table; and
 - (B) each individual result shall be equal to or above the lower limit for the classification or, if below the classification, within the mean of the result minus 20%.

If either criteria is not met, the lot shall be considered to be of lower classification.
- (b) The classification in accordance with Table 2 shall be determined by—
 - (i) selecting and testing at least five specimens at random as specified in Appendices A and B of AS 4586; or
 - (ii) carrying out continuous testing and process control in accordance with AS 3942.
- (c) When testing individual lots, if a particular test fails to produce the expected classification it shall be permissible to—
 - (i) disregard the first sample, resample a minimum of 10 specimens from the whole lot, retest and apply the criteria to the new sample; or
 - (ii) subdivide the lot into smaller lots of different quality, resample, retest and reclassify each of the smaller lots.



Accredited for compliance with ISO/IEC 17025 – Testing
NATA is a signatory to the ILAC Mutual Recognition Arrangement for the mutual recognition of the equivalence of testing, medical testing, calibration and inspection reports

DRY FLOOR FRICTION SLIP RESISTANCE TEST
Ecoglo Guidance Strip G6-003

Prepared for: Ecoglo International Ltd
ATTENTION: Mark Watson
77 Kingsley Street
CHRISTCHURCH NZ 8240

Specimen Description: Ecoglo Guidance Strip G6-003 26x300 mm.

No. of Specimens: 8 off (Sampling conducted by client).

Specimen Preparation: Washed with water and pH neutral detergent, rinsed then dried.

Test Condition & Slope: Unfixed. Slope - Not Applicable.

Test Direction: Test conducted parallel with surface profile.

Air Temperature: 21°C

Test Standard: AS 4586: 2013 Slip resistance classification of new pedestrian surface materials, Appendix B - Dry Floor Friction Test.

Test Location: ATTAR, Unit 1, 64 Bridge Road, Keysborough, VIC.

Test Date: 11 December 2019

Test Equipment: Tortus Floor Friction Tester Mk II, Serial Number 154.

Slider Rubber: Slider 96 Batch #91 prepared on P400.

Test Personnel: Awel Guled

Run:	1	2
Coefficient of Friction (COF):	0.61	0.55
Mean COF (rounded to 0.05):	0.60	
Classification:	D1	

These results apply only to the specimens tested and it is recommended that before selection of flooring or paving materials the effect of service conditions, including maintenance procedures and wear on their slip-resistance be checked.

Prepared by:



Awel Guled
Compliance & Test Technician
Approved Signatory

Reviewed by:



Dale Siegle
Compliance and Test Technician
Approved Signatory

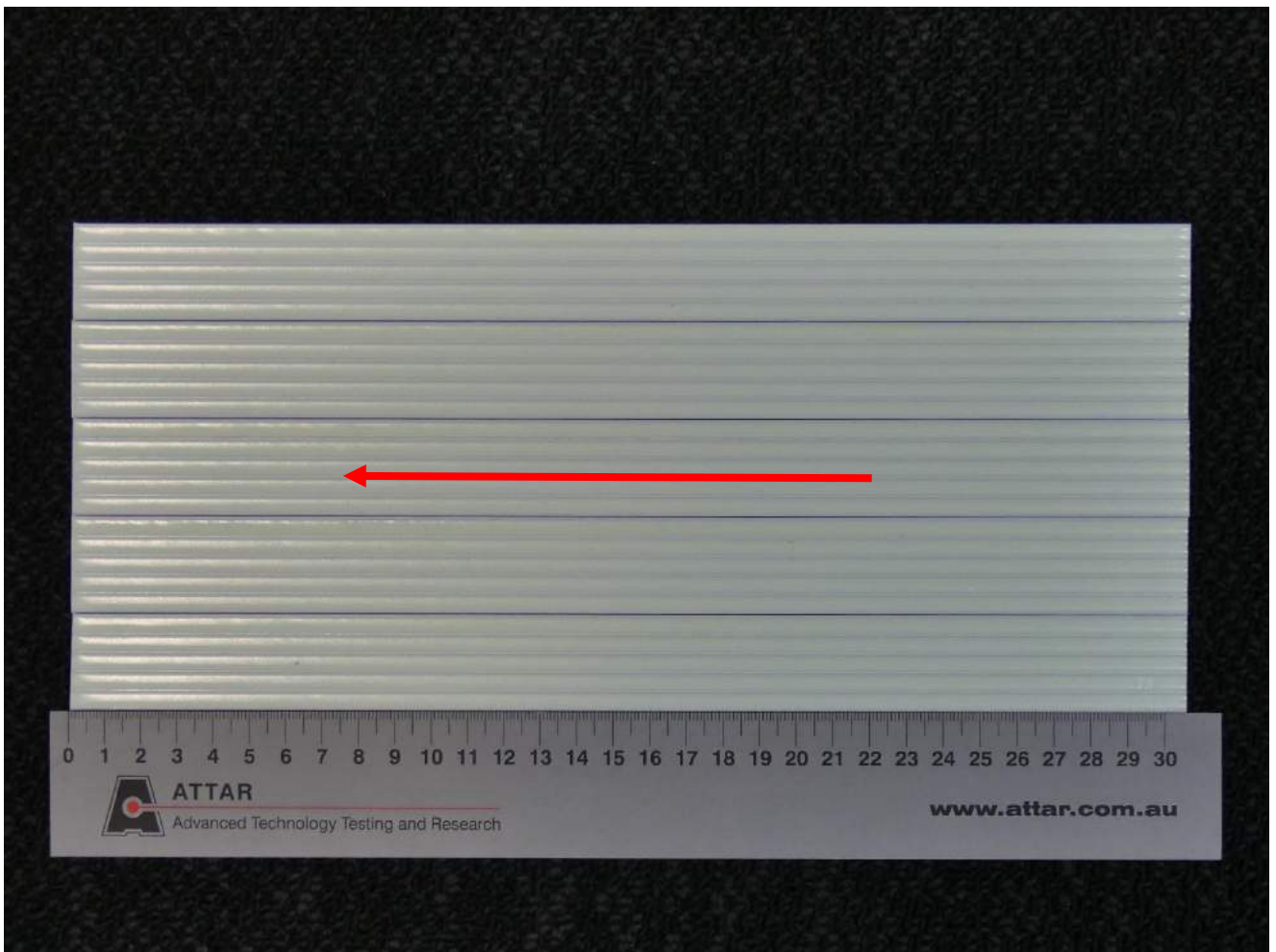

Figure 1: Ecoglo Guidance Strip G6-003.
Arrow indicates direction of test.

CLASSIFICATION CRITERIA – AS 4586: 2013
Dry Floor Friction Test - Appendix B

Slip resistance

The 'dry floor friction' test method in Appendix B is not suitable for heavily profiled surfaces or carpets.

Compliance

The surface shall comply with the stated classification for the test method that is nominated and declared by the manufacturer or supplier.

**TABLE 3: CLASSIFICATION OF PEDESTRIAN SURFACE MATERIALS
 ACCORDING TO THE AS 4586 DRY FLOOR FRICTION TEST**

Classification	Floor friction tester mean value
D1	≥0.40
D0	<0.40

Means of demonstrating compliance

Pedestrian surfaces that are classified in accordance with Table 3 where appropriate, shall meet the following criteria:

- (a) The mean test results shall be as follows:
 - (i) For Classification D1 in Table 3—
 - (A) the mean of the test results shall be equal to or greater than 0.4; and
 - (B) each individual slope corrected result shall be equal to or greater than 0.35.

If either of these criteria is not met, the lot shall be considered to be Classification D0.
- (b) The classification in accordance with Table 3 shall be determined by—
 - (i) selecting and testing specimens at random as specified in Appendix B of AS4586; or
 - (ii) carrying out continuous testing and process control in accordance with AS 3942.
- (c) When testing individual lots, if a particular test fails to produce the expected classification it shall be permissible to—
 - (i) disregard the first sample, resample a minimum of 10 specimens from the whole lot, retest and apply the criteria to the new sample; or
 - (ii) subdivide the lot into smaller lots of different quality, resample, retest and reclassify each of the smaller lots.



SINCE 1888

REPORT



ETL SEMKO

3933 US ROUTE 11 CORTLAND, NEW YORK 13045

Order No. 3078911

Date: November 15, 2005

REPORT NO. 3078911CRT-006

TEST OF FOUR PHOTOLUMINESCENT MATERIAL MODELS

RENDERED TO

ECOGLO LTD.
77 KINGSLEY ROAD
CHRISTCHURCH, NEW ZEALAND 8002

DATA REQUESTED

Luminance measurements after activation tests on four photoluminescent material models after UV exposure in accordance with New York City Building Code Reference Standards RS 6-1 and RS 6-1A: Photoluminescent Low-level Exit Path Markings.

AUTHORIZATION

This test service was authorized by signed quote number 18761099.

DEVICES SUBMITTED

The client submitted three photoluminescent material samples each of four Models: G3001C/E2071C, and G5001C/H5001C. The samples were received by Intertek on June 18, 2005 in undamaged condition, and tested as received. The sample designations are E2218Z through E2223Z.

DATE OF TESTS

June 28, 2005 through November 13, 2005.

TEST SUMMARY

NYC Building Code RS 6-1A Photoluminescent Low-level Exit Path Markings	Model G3001C/E2071C	Model G5001C/H5001C
Clause 1.0 Brightnes Rating Post UV Exposure	Complies	Complies

An independent organization testing for safety, performance, and certification.

This report is for the exclusive use of Intertek's Client and is provided pursuant to the agreement between Intertek and its Client. Intertek's responsibility and liability are limited to the terms and conditions of the agreement. Intertek assumes no liability to any party, other than to the Client in accordance with the agreement, for any loss, expense or damage occasioned by the use of this report. Only the Client is authorized to copy or distribute this report and then only in its entirety. Any use of the Intertek name or one of its marks for the sale or advertisement of the tested material, product or service must first be approved in writing by Intertek. The observations and test results in this report are relevant only to the sample tested. This report by itself does not imply that the material, product, or service is or has ever been under an Intertek certification program. Measurement uncertainty budgets have been determined for applicable test methods and are available upon request.

EQUIPMENT LIST

Equipment Used	Model Number	Control Number	Calibration Date
Optronic Luminance Standard	455-6-2	Y174	09/30/04
Optronic based Luminance Meter consisting of:			
Optronic Photometer	730C	E290	06/23/05
Optronic Direct Viewing Module	600	---	---
Optronic Amplified Photodetector	730-5H-LED	---	---
Fisher Scientific Stopwatch	---	N853	05/05
UDT Illumination Meter	S371R	L060	09/02/04

TEST AND TEST METHODSelective Process

After evaluation at Intertek, it was determined that Models G3001C and E2071C are identical in regards to luminance performance and that Models G5001C and H5001C are identical in regards to luminance performance.

Luminance Measurements Before and After Weathering Test

The luminance measurements were made on the photoluminescent test samples with the Intertek License Plate Test Apparatus. The center of each test sample was measured at normal (0°) viewing angle. The aperture of the Optronic based luminance meter was adjusted in order to view the maximum area on the test sample. The Intertek License Plate Test Apparatus consists of a Optronic based luminance meter and a horizontal and vertical movement system. The luminance calibration of the luminance meter is traceable to the National Institute of Standards and Technology through the calibration of the Optronic Luminance Standard.

The test samples were conditioned for at least 16 hours at zero footcandle illumination. The photoluminescent material samples were then conditioned for 120 minutes (two hours) by 2 footcandle illumination from a 4100K fluorescent light source. Luminance measurements were made on each test sample at two minutes intervals after conditioning for a period of one hour and at ninety minutes after conditioning. Luminance measurements were reported for ten minutes, sixty minutes and ninety minutes after conditioning.

Weathering Tests

The test samples were sent to Canesis Network Limited for 1000 hours exposure to Xenon Arc light apparatus per ASTM G155 Cycle 1. The samples were returned to Intertek for the post UV luminance measurements. Average post UV luminance measurements must be at least 90% of the initial average luminance measurements at each time interval.

Checked by: 

RESULTS OF TESTLuminance Measurements After Two Hours Activation Period

Model No. G5001C/H5001C
Intertek Sample Nos. E2220Z, E2218Z, E2219Z
 Luminance (mcd/m²)

Time After Exposure	Sample One	Sample Two	Sample Three	Average	Specified Minimum
<u>Pre UV Exposure</u>					
Ten Minutes	41.1	40.8	42.3	41.4	30
One Hour	9.96	9.66	10.25	9.96	7.0
Ninety Minutes	6.56	6.37	6.78	6.57	5.0
<u>Post UV Exposure</u>					
Ten Minutes	37.6	37.5	36.9	37.3	37.3*
One Hour	10.09	9.54	10.19	9.94	8.96*
Ninety Minutes	6.97	6.41	7.02	6.80	5.91*

Model No. G3001C/E2071C
Intertek Sample Nos. E2222Z, E2221Z, E2223Z
 Luminance (mcd/m²)

Time After Exposure	Sample One	Sample Two	Sample Three	Average	Specified Minimum
<u>Pre UV Exposure</u>					
Ten Minutes	105.6	104.7	107.3	105.9	30
One Hour	29.0	28.5	29.2	28.9	7.0
Ninety Minutes	20.2	19.7	20.1	20.0	5.0
<u>Post UV Exposure</u>					
Ten Minutes	99.1	97.2	100.0	98.8	95.3*
One Hour	27.3	28.4	27.6	27.8	26.0*
Ninety Minutes	18.1	19.4	18.4	18.6	18.0*

* Specified minimum is 90% of average initial luminance value at each time interval

In Charge Of Tests:

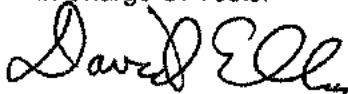

David Ellis
 Project Engineer
 Photometric Testing

Report Reviewed By:



Ernest Dykeman
 Senior Project Engineer
 Photometric Testing

Attachment: None



Scientific Services
Laboratory

Report No: XC2278/R1

TEST REPORT
SALT SPRAY TESTING OF STAIR NOSING

File: BPB/MISC

1. SAMPLE DETAILS

Client: Delwyn Ralston
LincLab Ltd
Private Bag 4749
Christchurch New Zealand

Sample Details: Five samples of aluminium stair nosings with anti-slip and photoluminescence inserts.

Requirements: To determine the salt spray resistance on the stair nosing.

2 TEST DETAILS-NATA REGISTRATION 219

2.1 Salt Spray

The samples were exposed in a Singleton Model 21 Salt Spray Cabinet for 500 hours. A second sample of 120201 J was kept as a reference sample. The salt spray testing was carried out in accordance with ASTM B117-97 'Standard Test Method of Salt Spray (Fog) Testing'.

2.2 Evaluation

After exposure, the samples were evaluated in accordance with ASTM D1654-92 'Evaluation of Painted or Coated Specimens Subject to Corrosive Environment. The degree of corrosion was determined in accordance with ASTM D610. The anti-slip properties were assessed visually at 10 x magnification. The photoluminescence of the exposed samples was compared with that of the reference sample in a dark room.

3 RESULTS

Sample No	XC 2278/F	XC 2278/G	XC 2278/H	XC 2278/I	XC 2278/J
Details	Aluminium stair nosing Labelled 120201F	Aluminium stair nosing Labelled 120201G	Aluminium stair nosing Labelled 120201H	Aluminium stair nosing Labelled 120201I	Aluminium stair nosing Labelled 120201J
Degree of Corrosion	0.5 % (Rating 9)	0.3 % (Rating 9)	0.3 % (Rating 9)	0.2 % (Rating 9)	0.2 % (Rating 9)
Anti Slip Properties	No deterioration observed	No deterioration observed	No deterioration observed	No deterioration observed	No deterioration observed
Photo - luminescence	No deterioration observed	No deterioration observed	No deterioration observed	No deterioration observed	No deterioration observed

G. Eccleston

G Eccleston
Senior Materials Scientist
9 April 2001



National Association of Testing
Authorities, Australia

NATA Endorsed Test Report
This document may not be
reproduced except in full.

AS/NZS ISO 9001 Quality System Certified Organisation

177 Salmon St, Port Melbourne, Vic. 3207 Telephone (03) 9248 4900 Fax (03) 9646 5165
A Business Unit of the Australian Government Analytical Laboratories (AGAL)
Industry, Science and Resources



TEST REPORT

DATE: 07/07/2005

TEST NUMBER: 096346

CLIENT	Ec o g lo Ltd
---------------	---------------

TEST METHOD CONDUCTED	ASIM D4828 Washability of Organic Materials
------------------------------	---

DESCRIPTION OF TEST SAMPLE	
IDENTIFICATION	E2071
COLOR	Photoluminescent
ROLL	-----
CONSTRUCTION	-----
FIBER	-----
BACKING	-----
REFERENCE	

GENERAL PRINCIPLE

This test method covers the determination of the relative ease of removal of common soil and stains from interior coatings. The stains used in this procedure include: crayon, pen, lipstick, and 3M soil. The soilants are applied to the material and are subsequently removed manually using a sponge and liquid cleaner. The area stained is rated for color change and the number of cleaning cycles reported at the point of complete removal. Three replicates of each stain were applied with the results reported as the average of all three ratings.

TEST RESULTS

	Crayon	Felt Tip Pen	Lipstick	3M soil
Gloss Change	None	None	None	None
Color Change	None	None	None	None
Erosion	None	None	None	None
Cycles to Clean	74	7	31	14
Rating	10	10	10	10

NOTE: This sample **PASSES** the requirements as listed in the New York Department of Buildings RS6-1A section 6-1A 2.0

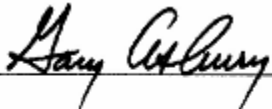
APPROVED BY: 

This report is provided for the exclusive use of the client to whom it is addressed. It may be used in its entirety to gain product acceptance from duly constituted authorities. This report applies only to those samples tested and is not necessarily indicative of apparently identical or similar products. This report, or the name of Professional Testing Laboratory Inc. shall not be used under any circumstance in advertising to the general public.



TEST REPORT

DATE: 07/07/2005

TEST NUMBER: 096346

CLIENT	Ec o g l o Ltd
--------	----------------

TEST METHOD CONDUCTED	ASIM D635 Standard Test Method for Rate of Burning and or Extent and Time of Burning of Self-Supporting Plastics in a Horizontal Position
-----------------------	---

DESCRIPTION OF TEST SAMPLE	
IDENTIFICATION	E2071
COLOR	Photoluminescent
ROLL	-----
CONSTRUCTION	-----
FIBER	-----
BACKING	-----
REFERENCE	

GENERAL PRINCIPLE

This method covers a small scale procedure for comparing the relative rate of burning and the extent and time of burning of self-supporting plastics that are tested in the horizontal position. A bar of the material is supported at one end. The free end is exposed to a gas flame for 30 seconds. The time and extent of burning are measured and reported. An average burn rate is reported over ten test specimens.

TEST RESULTS

	Burn Rate	Time of Burn	Extent of Burn
Specimen 1	No Burn Rate	0 Seconds	Did Not Ignite
Specimen 2	No Burn Rate	0 Seconds	Did Not Ignite
Specimen 3	No Burn Rate	0 Seconds	Did Not Ignite
Specimen 4	No Burn Rate	0 Seconds	Did Not Ignite
Specimen 5	No Burn Rate	0 Seconds	Did Not Ignite
Specimen 6	No Burn Rate	0 Seconds	Did Not Ignite
Specimen 7	No Burn Rate	0 Seconds	Did Not Ignite
Specimen 8	No Burn Rate	0 Seconds	Did Not Ignite
Specimen 9	No Burn Rate	0 Seconds	Did Not Ignite
Specimen 10	No Burn Rate	0 Seconds	Did Not Ignite
Average	No Burn Rate	0 Seconds	Did Not Ignite

APPROVED BY:

Gary Anthony

This report is provided for the exclusive use of the client to whom it is addressed. It may be used in its entirety to gain product acceptance from duly constituted authorities. This report applies only to those samples tested and is not necessarily indicative of apparently identical of similar products. This report, or the name of Professional Testing Laboratory Inc. shall not be used under any circumstance in advertising to the general public.

CALIFORNIA INSTITUTE OF ELECTRONICS AND MATERIALS SCIENCE
 2115 Flame Tree Way, Hemet, CA 92545 • Phone: 951 929 2659; Fax: 951 929 1057 • www.ciems.com

JALITE USA P. O. No. APR 15 of APRIL 15, 2005

DIVISION OF ELECTRONIC MEASUREMENTS AND DEVICES

Page 1 of 2

TEST REPORT
 NO. 850850821B of 20 MAY 2005

BRIGHTNESS, RADIOACTIVITY AND FLAME SPREAD TEST

Table 1. LUMINANCE TEST (Contact Method)

No.	Sample	Tested Area Geometry		Excitation		Luminance (Brightness), mcd/m ² after the time period of		
		Diameter mm	Area cm ²	Duration min	Illuminance lx	10 min	60 min	90 min
1	Ecoglo-G3001c	56.39	25.0	120.0	21.63	111	28.8	19.7

CONCLUSION: 1. *The tested samples of Ecoglo-G3001c meet the requirements of NYC Building Code Ref. STD RS 6-1, para. 1.4.*
 2. *The material tested has the Brightness Rating of 111-29-20.*

Table 2. RADIOACTIVITY TEST

No.	Material	Test Result, μSv/hr			Comments
		α-count	β-count	γ-count	
1 radioactive	Ecoglo-G3001c	<0.01	<0.01	<0.01	Non-

CONCLUSION: *The tested samples of Ecoglo-G3001c meet the requirements of NYC Building Code Ref. STD RS 6-1, para. 4.2.*

(continued on page 2)

3. FLAME SPREAD TEST

No.	Material	Test Parameters		Flame Spread	Flame Spread	Comments
		Temperature Drop $\Delta T, K$	Spec. Temperature Rise, $\beta, K/kW$	Factor, F_s 1	Index, I_s 1	
1	Ecoglo-G3001c	21.5	31.4	1.51	7.59	Ignites with difficulties

CONCLUSION: *The tested samples of Ecoglo-G3001c meet the requirements of NYC Building Code Ref STD RS 6-1, para. 5.2.*

TEST DESCRIPTION

- The test per ISO 17398:2000, Clause 7.11 and NYC BC Ref. STD RS-1, para. 1.1 - 1.4 (brightness); ASTM D3648 and NYC BC Ref. STD RS-1, para. 4.1 - 4.2 (radioactivity); and ASTM E162 and NYC BC Ref. STD RS 6-1, para. 5.1 - 5.2 (flame spread). Test conditions: T=22°C, RH=47±2%, P=101.0±0.2 kPa.
- The samples were preconditioned for the luminance test in the dark chamber and being wrapped in the black photographic paper for 63 hours, and were removed from the chamber immediately before the test. The test was performed in the windowless room lighted with the red photo-processing light. The excitation fluorescent light source has the maximum equivalent radiation intensity of $1.94 \cdot 10^7 \text{ W/m}^2$ ($4.3 \cdot 10^3 \text{ K}$) with $\lambda_{\text{max}}=674 \text{ nm}$.
- The radiation intensity readings were taken at nine different points on the surface of each of the samples tested with the samples located inside and outside of the radiation insulation chamber and under twelve angles between the normal to the sample surface and the direction of the field of gravity. The data in Table 2 were processed to exclude both the cosmic and the earth radiation background noise.
- The experimental error evaluated by the partial derivatives and least squares methods does not exceed 5%, 4% and 6.5% for the luminance, radioactivity and flame spread measurements, respectively. The data on the standard deviation are kept on file at CIEMS.

5. INSTRUMENTS AND DEVICES USED

- Digital Photometer Model 840006 SSL (0 to 20,000 lx), Digital Scotopic/Photopic Meter Model SL-3101 SLC
- Radiometer/Photometer Model DR-2000 w/Si Detector GS
- Goniometer Model 3501-08 FD
- Moseley X-Y Recorder Model 7035B HP
- 50A, 6V Stabilized Power Supply Model SC-506FAVD HBC
- Precision Micrometer Model 25/100 Krupp/Hommelwerke
- Radiation Pyrometer Model ST-30 Raynger
- Digital Timer Model Labchron-1402 LLI
- Programmed Temperature/Humidity Controller Model 100
- Geiger-Mueller Counter Model SGM-49C PRI

(continued on page 3)

- Scintillator Counter Model 111 PRI
 - Digital Nuclear Radiation Monitor Model DX-1 ITS
 - Flame Spread Testing Device Model 394-19DI BD
 - Digital Pyrometer Model Metis-MP25 SensorTherm GmbH (100°C - 700°C, 2.0 µm - 2.8 µm)
 - Optical Pyrometer Model MX-2 Raytek
 - IR Thermometer Model IR550 DKS
 - Precision Potentiometer/Thermometer Model 8659-AZ L&N
 - Microscopes: Model 9700 TSC, Model 500 PH, Model Tukon-300 Wilson
 - Starrett Dial Indicator Model 25-109 (1.27 µm/div)
 - Digital Hydrothermometer Model 63-844 MI, Barometer Model 602650 SB.
6. Reference materials used for the test setup calibration:
- NIST SRM 4233C (Cs-137-Ba-137m) - for the radiation measurements
 - NIST SRM 1002d ($I_s=153$, $Q=36.5$) - for the flame spread test.
7. The equipment used in the test meets the applicable NIST, ASTM, ASME, OSHA and State requirements and was calibrated with the standards traceable to the NIST. The calibration was performed per ANSI/ISO ASQ Q9004-2000, ISO 10012-1:1992, ISO 10012-2:1997, MIL-STD-45662, MIL-I-45208, NAVAIR-17-35-MTL-1, CSP-1/03-93 and the instruments manufacturers' specifications.
8. The equipment passed a periodic accuracy test in June 2004. The linear and volume measure instruments and equipment were calibrated in December 2004. Next test - June 2005.

TEST ENGINEER: 51

DIVISION MANAGER: *Cynthia Smythe*



BODYCOTE • 2395 SPEAKMAN DRIVE, MISSISSAUGA, ONTARIO, CANADA L5K 1B3 • TEL: (905) 822-4111 • FAX: (905) 823-1446

Bombardier SMP 800-C Toxic Gas Generation on "Ecoglo E2071" HPPL Composite

A Report To: **Professional Testing Laboratory, Inc.**
714 Glenwood Place
Dalton, GA 30721
USA

Phone: (706) 226-3283
Fax: (706) 226-6787

Attention: Lee Phillips

Submitted By: Fire Testing

Report No. 05-02-519
3 pages + 1 appendix

Date: July 12, 2005

ACCREDITATION Standards Council of Canada, Registration #1.

REGISTRATIONS

- ISO 9001:2000, registered by QMI, Registration #001109.
- New York City Department of Buildings, MEA Division, Registration #110-05-L.

SPECIFICATIONS OF ORDER

Determine toxic gas production according to Bombardier SMP 800-C, as per your P.O. #2005-062905 dated June 29, 2005.

IDENTIFICATION (BMTC sample identification number 05-02-S0519)

Composite, abrasive strip and high performance photoluminescent (HPPL) material on aluminum tracking substrate, approximately 2.1 to 2.4 mm in total thickness, identified as "Ecoglo E2071".

SAMPLE PREPARATION

Specimens were supplied as a two-material composite strip with two separate, and compositionally different materials attached to an aluminum tracking substrate. Since this strip represents the final product, it was determined that this test procedure was appropriate. Requisite specimen sizes were created by butting two strips of the material together vertically in the specimen holders, in alternate stripes, in an attempt to offer maximum exposure to both materials.



Far Left. Composite marking system shown as supplied (cut to length).

Right: Test specimen (2 sections butted together vertically) shown in sample holder with abrasive strip and HPPL ridges alternating.

TEST RESULTS

Bombardier SMP 800-C

Toxic Gas Generation

		Flaming <u>Mode</u>	Non-Flaming <u>Mode</u>	Specified <u>Maxima</u>
Carbon Monoxide (CO ppm)	at 1.5 minutes	<10	<10	-
	at 4.0 minutes	10	<10	-
	at maximum	463	<10	3500
Carbon Dioxide (CO2 ppm)	at 1.5 minutes	<50	<50	-
	at 4.0 minutes	1850	<50	-
	at maximum	13400	<50	90000

TEST RESULTS (Cont..)

Bombardier SMP 800-C

Toxic Gas Generation

	<u>Flaming Mode</u>	<u>Non-Flaming Mode</u>	<u>Specified Maxima</u>
Nitrogen Oxides (as NO2 ppm)	2	1	100
Sulfur Dioxide (SO2 ppm)	<1	<1	100
Hydrogen Chloride (HCl ppm)	7	9	500
Hydrogen Fluoride (HF ppm)	<2	<2	100
Hydrogen Bromide (HBr ppm)	<1	<1	100
Hydrogen Cyanide (HCN ppm)	2	<1	100
Original Weight (g) (including substrate)	24.8	24.4	-
Final Weight (g) (including substrate)	<u>20.9</u>	<u>24.2</u>	-
Weight Loss (g)	3.9	0.2	-
Weight Loss (%)	15.86	0.78	-
Time to Ignition (s)	125	Did not ignite	-
Burning Duration (s)	Not determinable	-	-

CONCLUSIONS

The photoluminescent composite material on aluminum identified in this report, when tested at a total approximate thickness of 2.1 to 2.4 mm, meets Bombardier requirements as they pertain to toxic gas production (Bombardier SMP 800-C) and therefore meets the toxicity requirements of paragraph 3.0 of the New York City Building Code § 27-383(b) Reference Standard RS 6-1A (Photoluminescent exit path markings).

Note: This is an electronic copy of the report. Signatures are on file with the original report.

I. Smith,
Fire Testing.

Richard J. Lederle,
Fire Testing.

Note: This report consists of 3 pages, including the cover page, that comprise the report "body". It should be considered incomplete if all pages are not present. Additionally, the Appendix of this report comprises a cover page, plus 1 page.

CERTIFICATE OF COMPLIANCE

Certificate Number SA45151
Report Reference SA45151-20190130
Issue Date 2020-JANUARY-03

Issued to: Ecoglo International Ltd
77 Kingsley St
Christchurch 8023 NEW ZEALAND

This certificate confirms that representative samples of LUMINOUS EGRESS-PATH-MARKING SYSTEMS
See Addendum Page

Have been investigated by UL in accordance with the Standard(s) indicated on this Certificate.

Standard(s) for Safety: UL 1994-Luminous Egress Path Marking Systems
CAN/ULC-S572-Photoluminescent and Self-Luminous Exit Signs and Path Marking Systems

Additional Information: See the UL Online Certifications Directory at <https://iq.ulprospector.com> for additional information.

This *Certificate of Compliance* does not provide authorization to apply the UL Mark. Only the UL Follow-Up Services Procedure provides authorization to apply the UL Mark.

Only those products bearing the UL Mark should be considered as being UL Certified and covered under UL's Follow-Up Services.

Look for the UL Certification Mark on the product.

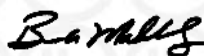

Bruce Mahrenholz, Director North American Certification Program
UL LLC

Any information and documentation involving UL Mark services are provided on behalf of UL LLC (UL) or any authorized licensee of UL. For questions, please contact a local UL Customer Service Representative at <http://ul.com/aboutul/locations/>



CERTIFICATE OF COMPLIANCE

Certificate Number SA45151
Report Reference SA45151-20190130
Issue Date 2020-JANUARY-03

This is to certify that representative samples of the product as specified on this certificate were tested according to the current UL requirements.

USL, CNL – Photoluminescent Floor proximity egress path marking systems,
Extruded aluminum products with photoluminescent compound applied Models
G3-001, G3001, G4-001, G4001, G6-001, G6001, G6-003, G5-001, G5001, H3-001, H3001, H5-003,
H5-001, H5001, E2-071, E2071, E2-061, E2061, E2-051, E2051, E2-031, E2031, E3-071, E3071, E3-
061, E3061, E3-051, E3051, E3-031, E3031, E4-073, E4-063, E4-053, E4-033, E4-071, E4071, E4-
061, E4061, E4-051, E4051, E4-031, E4031, E14-075, E14-065, E14-055, E14-035, E15-073, S5-
ARS1010, S5-DHM1010 and S5-ARD1010

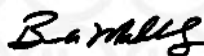

Bruce Mahrenholz, Director North American Certification Program
UL LLC

Any information and documentation involving UL Mark services are provided on behalf of UL LLC (UL) or any authorized licensee of UL. For questions, please contact a local UL Customer Service Representative at <http://ul.com/aboutul/locations/>



PRODUCT COVERED:

USL, CNL - Photoluminescent Floor proximity egress path marking systems, Extruded aluminum products with photoluminescent compound applied Models G3-001, G3001, G4-001, G4001, G6-001, G6001, G6-003, G5-001, G5001, H3-001, H3001, H5-003, H5-001, H5001, E2-071, E2071, E2-061, E2061, E2-051, E2051, E2-031, E2031, E3-071, E3071, E3-061, E3061, E3-051, E3051, E3-031, E3031, E4-073, E4-063, E4-053, E4-033, E4-071, E4071, E4-061, E4061, E4-051, E4051, E4-031, E4031, E14-075, E14-065, E14-055, E14-035, **E15-073**, S5-ARS1010, S5-DHM1010 and S5-ARD1010.

GENERAL:

This product complies with the Standard of Underwriters Laboratories Inc. for Luminous Egress Path Marking Systems (UL 1994) and the Description on the following pages.

These are photo-luminescent markers intended to be installed at or near the floor level of hallways and other areas in buildings to identify emergency egress routes.

The photo-luminescent materials are activated by exposure to existing ambient lighting. They have been evaluated for activation by fluorescent or LED lighting of minimum 1 foot-candle, and are so noted in the instructions provided.

TECHNICAL CONSIDERATIONS (NOT FOR FIELD REPRESENTATIVE'S USE):

USL - indicates product complies with the Standard for Luminous Egress Path Marking Systems, UL 1994.

CNL - These units were evaluated to the requirements of CAN-ULC-S572, Standard for Photoluminescent and Self-Luminous Exit Signs and Path Marking Systems.



Allunga Exposure Laboratory

Tel: + 61 7 4778 1697
Fax: +61 7 4422 0009
Lat 19°S, 147°E

Email: test@allunga.com.au
Web: www.allunga.com.au

Mail: Locked Bag 369, Aitkenvale
Mail Centre, Queensland,
AUSTRALIA 4814

Attention Delwyn Ralston
Ecoglo International Ltd
77 Kingsley St
Sydenham Christchurch 8023
New Zealand

Report Name Samples / 1-6 @ 20 min @ 150°C
Duration 20 min @ 150°C
Your Reference Samples / 1-6
Our Reference 20D06WW1-6
Report Date 07-Apr-2020

Exposure Type: See Below
Date Exposed 06-Apr-2020

Book & Page: 909/66
Site: Townsville (Main)

Authorised AEL Signatory: Chris Cooper

Notes:

EXPOSURE

Expose samples for 20 minutes at 150°C, as per client instructions.

Instrument: WiseVen WOF-105 Precision Laboratory Oven.

REPORT STANDARDS

VISUAL ASSESSMENT OF CHANGE

Based on Standard: AS/NZS 1580.481.1:1998 Coatings Exposed to Weathering (12 Parameters of Change)

Degree of colour change - AS/NZS 1580.481.1.12

Degree of Blistering - AS/NZS 1580.481.1.9 Blistering

Degree of distortion/shrinkage

AS/NZS, ISO Rating scale: 0-5. 0 = No change, 5 = Complete change

NOTE: AS/NZS 1580.481.1.9 Degree of Blistering

Rating is in two parts, Density (D) and Size (S)

Method 481.1.1.9: Degree of Blistering

0 = None

1 = Less than few

2 = Few

3 = Medium

4 = Medium-dense

5 = Dense

Note: Report prepared >24 Hours post exposure to allow any colour changes associated with energy absorption/radiation to dissipate. Photos taken at 45 minutes and at 24 hours.

Exposure conducted: 06 April 2020.

Report Prepared: 07 April 2020.

Evaluation based on As 1580.481

1.1 General Appearance
1.2 Discolouration
1.3 Dirt Collection
1.4 Dirt Retention
1.5 Change of Gloss
1.6 (E) Erosion
1.7 (F) Checking
1.8 (G) Cracking
1.9 (H) Flaking & Peeling

Colour: D65/10
1.9 (J) Blistering
(K) Visible Rusting
1.11 (L) Chalking
1.13 Mould, Algae, Fungus
FIC Ford Image Clarity
FD Film Defects
d Darker
l lighter
r redder

All Samples Tested As Received

b bluer
y yellow
g greyer
wh whiter
f fade
i increase
c continued
w wide variation
t trace

length measurements in mm

m includes mould
loc localized
nnc no noticeable change
sd surface distortion
ws water spotting
af adhesion failure
S slight
md moderate
sv severe



Allunga Exposure Laboratory

Tel: + 61 7 4778 1697
 Fax: +61 7 4422 0009
 Lat 19°S, 147°E

Email: test@allunga.com.au
 Web: www.allunga.com.au

Mail: Locked Bag 369, Aitkenvale
 Mail Centre, Queensland,
 AUSTRALIA 4814

Attention Delwyn Ralston
 Ecoglo International Ltd
 77 Kingsley St
 Sydenham Christchurch 8023
 New Zealand

Report Name Samples / 1-6 @ 20 min @ 150°C
Duration 20 min @ 150°C
Your Reference Samples / 1-6
Our Reference 20D06WW1-6
Report Date 07-Apr-2020

Exposure Type: See Below
Date Exposed 06-Apr-2020

Book & Page: 909/66
Site: Townsville (Main)

Authorised AEL Signatory: Chris Cooper

Client Ref	Colour Change	Blistering	Distortion
Hazard tape	0 t	0	1-2
G3-001	0	0	0
S5 sign (1)	0	0	0
S5 sign (2)	0	0	0
S20	0	0	0
A20	1 d g	-	5

Client Ref.	Comments
Hazard tape	Tape has an 'orange peel' wrinkling across whole surface. See photographs
A20	Sample melted onto substrate trapping air in small voids that subsequently expanded giving appearance of blistering, substrate distorted as sample cooled. Exposed material appears a trace darker and greener 24 hours after exposure. See photographs.

Evaluation based on As 1580.481

- 1.1 General Appearance
- 1.2 Discolouration
- 1.3 Dirt Collection
- 1.4 Dirt Retention
- 1.5 Change of Gloss
- 1.6 (E) Erosion
- 1.7 (F) Checking
- 1.8 (G) Cracking
- 1.9 (H) Flaking & Peeling

- 1.9 (J) Blistering
- (K) Visible Rusting
- 1.11 (L) Chalking
- 1.13 Mould, Algae, Fungus
- FIC Ford Image Clarity
- FD Film Defects
- d Darker
- l lighter
- r redder

Colour: D65/10

All Samples Tested As Received

- b bluer
- y yellower
- g greyer
- wh whiter
- f fade
- i increase
- c continued
- w wide variation
- t trace

length measurements in mm

- m includes mould
- loc localized
- nnc no noticeable change
- sd surface distortion
- ws water spotting
- af adhesion failure
- S slight
- md moderate
- sv severe

Appendix 4

Ecoglo International Ltd

Quality Assurance Document

Ecoglo International Ltd

QUALITY POLICY

E.I.L is a world leader in the manufacture of photoluminescent signage and path marking. We pride ourselves on our strong focus on compliance and durability. Our policy is to achieve sustainable growth by offering quality products and service. All of our staff are committed to continual quality improvement. The company has earned respect and credibility, at an international level, as a result of our contributions to building code development around photoluminescent system design.

E.I.L maintains an ISO 9001:2016 compliant Business Management System. Management will ensure that all staff are committed to the principles of this system and its continual development.

Our key objectives are:

- To ensure that all products meet contractual and relevant regulatory obligations, both national and international.
- To offer a cost effective and sustainable alternative to traditional electrical lighting that all areas of industry can adopt in a safe and practical manner.
- To offer the most durable photoluminescent products on the market and back them with the best warranty and after-sales support.
- To identify and implement new processes to reduce our product cost without increasing our environmental impact.

Our strategy to achieve these goals is:

- Maintain a high level of staff input on quality control.
- Focus on keeping our staff fully aware of our expected quality output.
- Explore all opportunities to improve our products and processes.
- Effectively recognise the limitations of our product range and work with our clients and competitors to deliver the best result for our clients.
- Be active and engaged in the wider fire safety industry.
- Review any complaints or criticism and use them to construct educational material that assists all levels of industry, both national and international.

Ecoglo International Ltd.

77 Kingsley Street
Christchurch, New Zealand
www.ecoglo.com

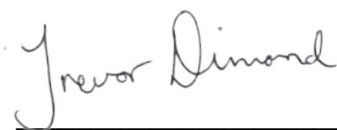
Signed: 
 Name: Trevor Dimond
 Date: 10 October 2019

Appendix 5

Ecoglo International Ltd

Warranties

Ecoglo International Limited

Warranty for Photoluminescent Performance of HTC* Signs and Products

1. We warrant the photoluminescent performance of both Signs and Products, manufactured using our High Temperature Curing (HTC) process, for a period of:

thirty years from the date of installation for standard Signs and Products which are positioned **indoors**; and

fifteen years from the date of installation for **outdoor** Signs (specially coated for **outdoor** conditions) and Products which are positioned **outdoors**.
2. This warranty assumes correct installation and normal conditions of use and maintenance but does not cover normal wear and tear. This warranty does not cover deterioration due to abuse, mistreatment, natural disasters (e.g. fire, flood), exposure to harmful chemicals or environments or any other use or exposure not recommended in our product literature. In particular, this warranty is void in the following circumstances:
 - 2.1 The Signs and/or Products have been misused, neglected, damaged, abused or involved in an accident.
 - 2.2 The Signs and/or Products have been improperly installed, operated, repaired or maintained.
 - 2.3 The Signs and/or Products have been modified.
 - 2.4 The Signs and/or Products have been used outside their stated specifications, capacity and operating parameters.
3. If you have a claim that, in our reasonable judgement, satisfies the terms of this warranty, we shall replace the defective Sign or Product (material only).
4. This is an express warranty. It is your sole and exclusive remedy. We disclaim any other express or implied warranties, including warranties of merchantability or fitness for purpose, to the maximum extent permitted by law. Under no circumstances shall we accept liability for any injury to persons, damage to property, loss of profits, loss of operations or other direct, indirect, special, incidental, or consequential losses, costs and damages whether incurred by you, your guests, licensees, invitees or other third parties. Our liability under any circumstance, whether in contract, tort or otherwise, shall not, in the aggregate, exceed the price that you paid for the Sign and/or Product.
5. Some countries do not allow certain disclaimers, limitations or exclusions in warranties. Therefore, the above disclaimers, limitations and exclusions may not apply to you. This warranty gives you specific legal rights. You may have other rights or remedies pursuant to the laws of your country. Nothing in this limited warranty should be construed as limiting or restricting any other right or remedy available to you, except as allowed by the law in your country.

*Manufactured using High Temperature Curing (HTC)

Ecoglo International Limited

Warranty for Photoluminescent Performance of Non-HTC (High Temperature Curing) Products

1. We warrant the photoluminescent performance of non-HTC Products for a period of:
three years from the date of installation for Products which are positioned **indoors only**.
2. This warranty assumes correct installation and normal conditions of use and maintenance but does not cover normal wear and tear. This warranty does not cover deterioration due to abuse, mistreatment, natural disasters (e.g. fire, flood), exposure to harmful chemicals or environments or any other use or exposure not recommended in our product literature. In particular, this warranty is void in the following circumstances:
 - 2.1 The Products have been misused, neglected, damaged, abused or involved in an accident.
 - 2.2 The Products have been improperly installed, operated, repaired or maintained.
 - 2.3 The Products have been modified.
 - 2.4 The Products have been used outside their stated specifications, capacity and operating parameters.
3. If you have a claim that, in our reasonable judgement, satisfies the terms of this warranty, we shall replace the defective Product (material only).
4. This is an express warranty. It is your sole and exclusive remedy. We disclaim any other express or implied warranties, including warranties of merchantability or fitness for purpose, to the maximum extent permitted by law. Under no circumstances shall we accept liability for any injury to persons, damage to property, loss of profits, loss of operations or other direct, indirect, special, incidental, or consequential losses, costs and damages whether incurred by you, your guests, licensees, invitees or other third parties. Our liability under any circumstance, whether in contract, tort or otherwise, shall not, in the aggregate, exceed the price that you paid for the Product.
5. Some countries do not allow certain disclaimers, limitations or exclusions in warranties. Therefore, the above disclaimers, limitations and exclusions may not apply to you. This warranty gives you specific legal rights. You may have other rights or remedies pursuant to the laws of your country. Nothing in this limited warranty should be construed as limiting or restricting any other right or remedy available to you, except as allowed by the law in your country.

Appendix 6

Ecoglo International Ltd

Maintenance and Cleaning Instructions

Instructions For

Maintenance and Cleaning

Exit Signs and Escape Path Markings



Maintenance and Cleaning Instructions For Exit Signs and Escape Path Markings

Overview

- Regular maintenance and cleaning to remove any obstructions or built up dirt and deposits will ensure the Ecoglo products continue performing to expectation.
- The photoluminescence will continue performing even after UV exposure or exposure to moisture.

Floor Mounted Products

- Check nothing is covering up the product.
- Visually inspect for any sign of damage.
- Vacuuming or brushing with a stiff bristle head brush (dry or wet) is often enough to keep the strips clean.
- The glowing strip can also be wiped clean with a (dry or wet) sponge or cloth.
- High-pressure water (but not steam cleaning) can also be used.
- Observation will determine if cleaning is required however a regular clean every 4 to 6 weeks or after particularly heavy use should ensure correct performance.

Wall Mounted Products

- Check nothing is covering up the sign.
- Visually inspect for any sign of damage.
- Dusting with a soft cloth or brush is often enough to keep the signs clean.
- The glowing material can also be wiped clean with a (dry or wet) sponge or cloth.
- Observation will determine if cleaning is required.

Note

- Do not use highly alkaline or acidic cleaning agents. The pH of the cleaning agents should be between pH 5 and pH 12.
- If cleaning agents are applied at more than pH 10, the Ecoglo material should be rinsed with pH neutral (pH 6 to pH 8) solution afterwards.

For more detailed information re inspection and maintenance procedures for signs please see Photoluminescent Lighting Council Standard PLCS 101 2019, Part C - Inspection and Maintenance (available for download from the Homepage at www.plcouncil.com.au)

Ecoglo International Limited

Email: info@ecoglo.com

Web: www.Ecoglo.com

